

## New products for machining technicians

### **NEW** BluFlex 2



It gets even better

As well as its unbeatable, innovative and highly precise characteristics, the BluFlex 2 system also boasts a modern high contrast OLED display. The MicroKom BluFlex 2 app and the Bluetooth-capable precision adjustment head ensure incredibly simple handling.

### **NEW** hi.flex



The hi.flex system distinguishes itself with its high flexibility. With just a single adjustable head, a variety of boring bars and intelligently designed adapter solutions, it covers the entire diameter range from 6 to 365 mm.

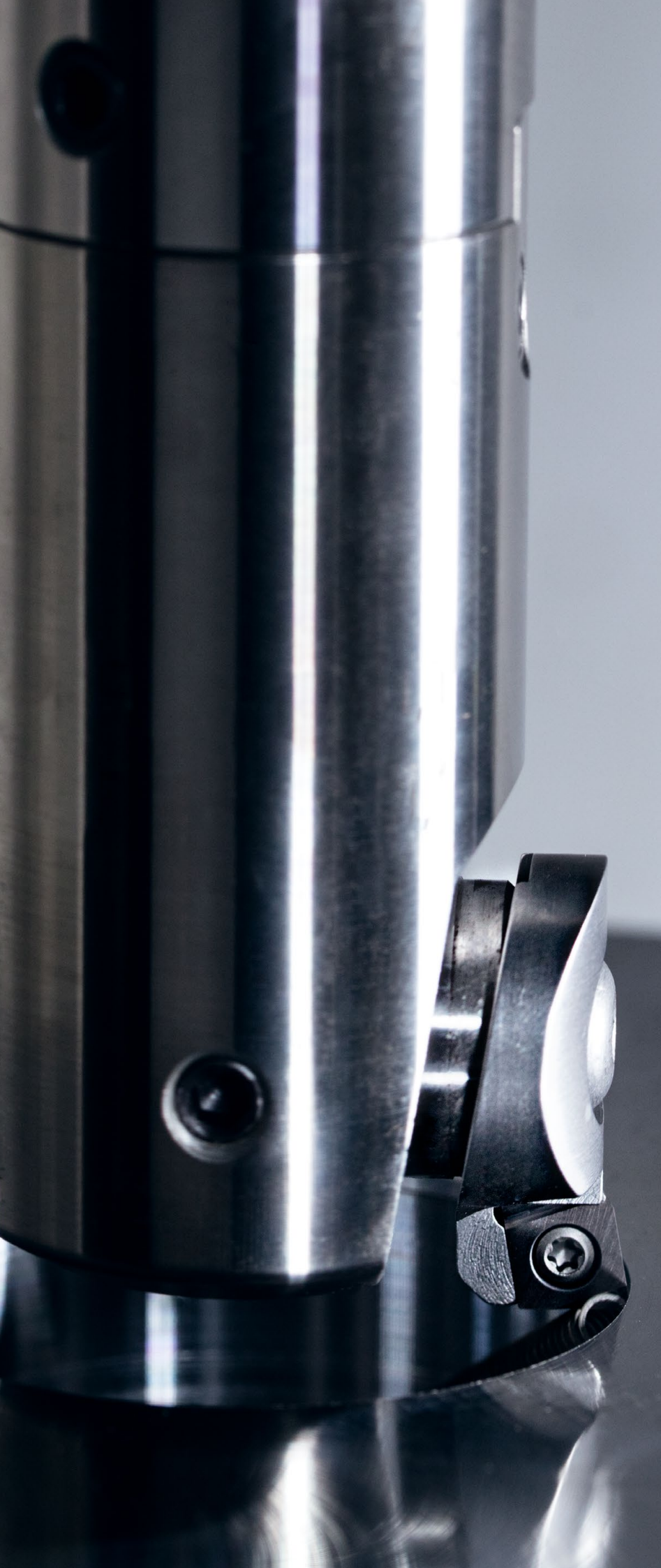

Solid drilling and bore machining

1 HSS drilling

2 Solid carbide drilling

3 Indexable insert drilling

4 Reaming and Countersinking

5 Spindle Tooling

5

Threading

6 Taps and thread formers

7 Circular and Thread Milling

8 Thread turning

Turning

9 Turning Tools

10 EcoCut

11 Grooving Tools

12 Miniature turning tools

Milling

13 HSS Milling Cutters

14 Solid Carbide milling cutters

15 Milling tools with indexable inserts

Tool Clamping

16 Adapters

17 Accessories

18 Material examples and article no. index

## Table of contents

Symbol explanation	2
Toolfinder	3
Contents Overview Accessories	4
Product programme	5-48
Technical Information	
Cutting Data	49-53
Maximum Speeds and Scale Accuracy	54
Maximum overhang length LTA	55
Coatings	55

## KOMET \ Performance

Premium quality tools for high performance.

The premium quality tools from the **KOMET Performance** product line have been designed for specific applications and are distinguished by their outstanding performance. If you make high demands on the performance of your production and want to achieve the very best results, we recommend the Premium tools in this product line.

## Symbol explanation

<b>F</b>	Fine Machining
<b>M</b>	Medium Machining
<b>R</b>	Rough Machining

	Smooth cut
	Irregular cutting depth
	Interrupted cut



Central internal coolant



Axial coolant (Form AD)



Coolant supply either via the flange or centrally



**KOMET ABS** – modular coupling system for rotating and stationary tools



**STM** Modular SpinTools interface



**ER 32** System-independent ER 32 interface

Micron-precise display resolution: 0.001 mm in diameter

Modern, high contrast OLED display on the precision adjustment head itself



Universal ABS interface

Absolute position measuring system







Additional Bluetooth Low Energy interface for easy display on any conventional smartphone

# Toolfinder





System	Diameter range per head in mm	Digital	Analogue	ABS Modular	STM Modular	ER 32 Modular	Monoblock	Through spindle	Comments	Pages					
Machining	Finishing	 BluFlex 2 – precision adjustment head 6,0–125 mm	6,0–125					<input checked="" type="checkbox"/>	<input type="checkbox"/>	<input checked="" type="checkbox"/>	<input type="checkbox"/>	<input type="checkbox"/>	<input checked="" type="checkbox"/>	Through spindle larger head diameters	5–8
		 hi.flex – precision adjustment head 6,0–125 mm	6,0–125					<input type="checkbox"/>	<input checked="" type="checkbox"/>	<input checked="" type="checkbox"/>	<input type="checkbox"/>	<input type="checkbox"/>	<input checked="" type="checkbox"/>	Through spindle larger head diameters	5–8
		 Micro Boring Head 0,3–19,1 mm	0,3–7,1	0,3–19,1				<input checked="" type="checkbox"/>	<input checked="" type="checkbox"/>	<input type="checkbox"/>	<input type="checkbox"/>	<input type="checkbox"/>	<input type="checkbox"/>		12+13
		 Fine boring head 14,7–24,1 mm	14,7–17,1	16,7–20,1	19,7–24,1			<input type="checkbox"/>	<input checked="" type="checkbox"/>	<input type="checkbox"/>	<input type="checkbox"/>	<input type="checkbox"/>	<input checked="" type="checkbox"/>		14+15
		 Multi-Head – Fine boring head 3,0–320 mm	3,0–320					<input type="checkbox"/>	<input checked="" type="checkbox"/>	<input checked="" type="checkbox"/>	<input checked="" type="checkbox"/>	<input checked="" type="checkbox"/>		Through spindle larger head diameters	16+17
		 Single point boring head 3,0–88,1 mm	3,0–88,1					<input checked="" type="checkbox"/>	<input checked="" type="checkbox"/>	<input type="checkbox"/>	<input checked="" type="checkbox"/>	<input checked="" type="checkbox"/>	<input checked="" type="checkbox"/>	Through spindle larger head diameters	18–26
		 Single point finish boring heads 23,9–116,1 mm	23,9–31,1 86,9–116,1	30,9–40,1	39,9–51,1	50,9–67,1	66,9–87,1	<input checked="" type="checkbox"/>	<input checked="" type="checkbox"/>	<input checked="" type="checkbox"/>	<input type="checkbox"/>	<input type="checkbox"/>	<input checked="" type="checkbox"/>		27–29
		 Vario-Head – boring and fine boring head 3–152 mm	3–152					<input checked="" type="checkbox"/>	<input type="checkbox"/>	<input checked="" type="checkbox"/>	<input type="checkbox"/>	<input type="checkbox"/>	<input type="checkbox"/>		30+31
		 Single point finish boring heads 86–402 mm	86–402					<input type="checkbox"/>	<input checked="" type="checkbox"/>	<input checked="" type="checkbox"/>	<input type="checkbox"/>	<input type="checkbox"/>	<input checked="" type="checkbox"/>		32+33
		 Console tool with baseplate 150–655 mm	150–205 150–205	200–255 200–255	250–305 250–305	300–355 300–355	350–405 350–405	<input type="checkbox"/>	<input checked="" type="checkbox"/>	<input type="checkbox"/>	<input type="checkbox"/>	<input type="checkbox"/>	<input checked="" type="checkbox"/>	also available with roughing head	
		 Console tool with slide 650–2205 mm	650–1105	1100–1655	1650–2205			<input type="checkbox"/>	<input checked="" type="checkbox"/>	<input type="checkbox"/>	<input type="checkbox"/>	<input type="checkbox"/>	<input checked="" type="checkbox"/>	also available with roughing head	
Roughing	Roughing - Finishing	 Twin edged rough / fine boring head 29,5–115,5 mm	29,5–40,1	39,5–50,5	49,5–66,5	65,5–87,5	86,5–115,5	<input type="checkbox"/>	<input checked="" type="checkbox"/>	<input checked="" type="checkbox"/>	<input type="checkbox"/>	<input checked="" type="checkbox"/>		34+35	
		 Twin rough boring head 23,5–153,0 mm	23,5–30,5 86,5–115,5	29,5–40,1 114,5–153,0	39,5–50,5	49,5–66,5	65,5–87,5	<input type="checkbox"/>	<input checked="" type="checkbox"/>	<input checked="" type="checkbox"/>	<input type="checkbox"/>	<input checked="" type="checkbox"/>		36–38	



 This article can be found in our online shop at [cuttingtools.ceratizit.com](http://cuttingtools.ceratizit.com)

## Overview of base adapters and accessories

					
System		DIN 69871	MAS-BT	HSK-A	Cylindrical shank
Base adapter		<b>ABS</b>	<b>i</b> ABS base adapters can be found in → <b>Chapter 16, Adapters.</b>		
Base adapter		<b>STM</b>	40	41	42 43

## Accessories

Extension		<b>STM</b>	46
Reduction		<b>STM</b>	44+45
Collet Chuck		<b>STM</b>	39
Shell mill adapter		<b>STM</b>	39

General	
Balancing rings	 24
Insert	 9-11 47+48

# MicroKom – BluFlex 2 – precision spindle head

▲ Via the App, the MicroKom BluFlex 2 display in the head can also be transferred to a standard smartphone (62 840 16097)

**Scope of supply:**

incl. Battery

**ABS**

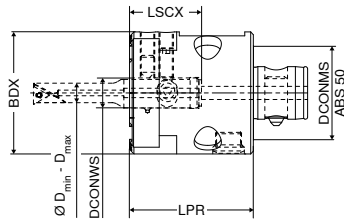

5

D <sub>min</sub> - D <sub>max</sub> mm	KOMET no.	Adapter	DCONWS	DCONMS	BDX	LPR	LSCX	without Bluetooth		with Bluetooth	
								NEW W4	NEW W4		
6 - 125	M0430100	ABS 50	16	28	65	71	38	Article no. 62 820 ...	Article no. 62 840 ...	£	£
6 - 125	M0430000	ABS 50	16	28	65	71	38	2,082.92	16097	2,082.92	16097

Spare parts for Article no.	XX		W7		W7		W7		W7			
	Image	Description	Article no.	Price	Image	Description	Article no.	Price	Image	Description	Article no.	Price
		Clamping screw	62 950 ...	£		Clamping screw	62 950 ...	£		Clamping screw	62 950 ...	£
										Clamping sleeve	62 950 ...	£
										Battery cover	62 950 ...	£
62 820 16097		M8x1x12/SW4	5.60	13989	M8x1x20/SW4	1.48	13700	M5x14/SW4	2.15	18600	6.19	18500
62 840 16097		M8x1x12/SW4	5.60	13989	M8x1x20/SW4	1.48	13700	M5x14/SW4	2.15	18600	6.19	18500

**i** Suitable ABS adapters can be found in → **Chapter 16, Adapters.**

# MicroKom – hi.flex – precision adjustment head

- ▲ For boring bars  $\varnothing$  16 mm and bridges
- ▲ With internal coolant supply
- ▲ LSCX = Boring depth

ABS

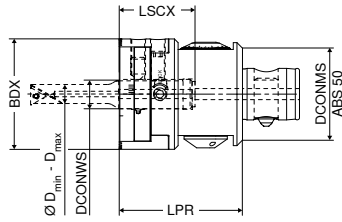

$D_{min} - D_{max}$ mm	KOMET no.	Adapter	DCONWS mm	DCONMS mm	BDX mm	LPR mm	LSCX mm	
6 - 125	M0501000	ABS 50	16	28	60	67	39.7	<div style="display: flex; align-items: center;"> <div style="margin-right: 5px;"><b>NEW</b></div> <div style="margin-right: 5px; border: 1px solid black; padding: 2px;">W4</div> <div style="margin-right: 5px;">Article no. <b>62 800 ...</b></div> <div style="margin-right: 5px;">£</div> <div style="margin-right: 5px;"><b>1,048.82</b></div> <div style="margin-right: 5px;">16097</div> </div>

Spare parts

for Article no.  
62 800 16097

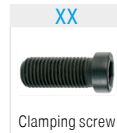

Clamping screw

Article no.  
**62 950 ...**

£ **5.60** 13989



Clamping screw

Article no.  
**62 950 ...**

£ **1.48** 14700



Clamping screw

Article no.  
**62 950 ...**

£ **1.48** 13700

**i** Suitable ABS adapters can be found in → **Chapter 16, Adapters.**

## MicroKom – Steel boring bar for hi.flex, BluFlex 2

▲ With internal coolant supply

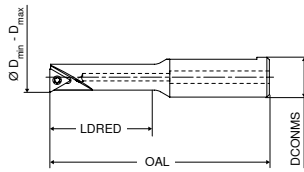

D <sub>min</sub> - D <sub>max</sub> mm	KOMET no.	OAL mm	LDRED mm	DCONMS <sub>h6</sub> mm	Insert	NEW W4	
						Article no.	£
6 - 8	B0520100	71.7	21.0	16	WO.. 02T0	112.83	00600
8 - 12	B0520120	77.4	28.0	16	TO.. 06T1	116.56	00800
10 - 14	B0520140	81.8	34.0	16	TO.. 0902	111.66	01000
12 - 18	B0520160	88.2	42.0	16	TO.. 0902	121.46	01200
14 - 18	B0520180	94.4	50.0	16	TO.. 0902	120.19	01400
18 - 25	B0520220	100.0	60.0	16	TO.. 0902	127.55	01800
22 - 26	B0520260	108.0	68.5	16	TO.. 1403	146.00	02200

**i** Suitable inserts can be found on → Page 9–11.

## MicroKom – Insert holder for serrated body hi.flex, BluFlex 2

▲ With internal coolant supply

Scope of supply:

- ▲ without inserts
- ▲ incl. mounting screws

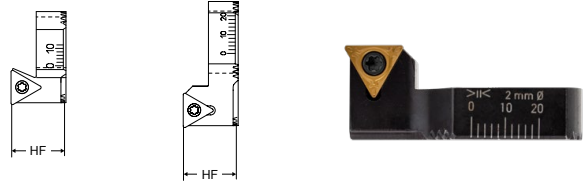

for	KOMET no.	HF mm	Insert	NEW W4	
				Article no.	£
62 861 06300	M0520101	13.5	TO.. 06T1	130.00	04400
62 861 06300 / 62 860 12500	M0520151	13.5	TO.. 0902	132.45	12500

**i** Suitable inserts can be found on → Page 10+11.

### Spare parts

Insert	Article no.	£
TO.. 06T1	12800	2.56
TO.. 0902	12000	2.23
TO.. 1403	12600	2.23
WO.. 02T0	11800	2.23

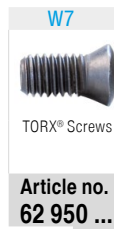

### Spare parts

for Article no.	Article no.	£
62 863 04400	09700	2.56
62 863 12500	09900	2.23

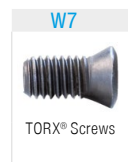

## MicroKom – Serrated body for hi.flex, BluFlex 2

▲ With internal coolant supply

Scope of supply:

without insert holder

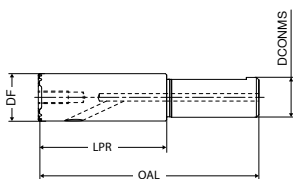

D <sub>min</sub> - D <sub>max</sub> mm	KOMET no.	DCONMS mm	OAL mm	LPR mm	DF mm	NEW W4	
						Article no.	£
25 - 63	M0590100	16	88.5	65	19	132.45	06300

### Spare parts

for Article no.	Article no.	£
62 861 06300	00000	0.83
	19100	1.48

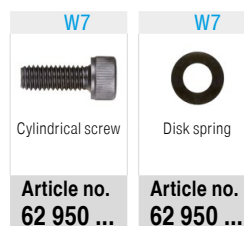

## MicroKom – Bridge for hi.flex, BluFlex 2

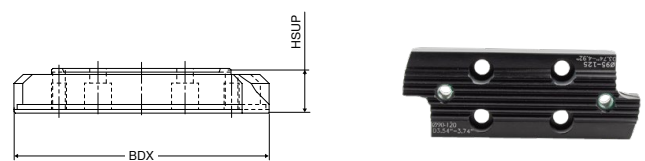

D <sub>min</sub> - D <sub>max</sub> mm	KOMET no.	BDX mm	HSUP mm	WT kg	NEW W4	
					Article no.	£
90 - 125	M0580101	85	12	0.147	182.78	12500

### Spare parts

for Article no.	Article no.	£
62 860 12500	00000	0.83
	19100	1.48

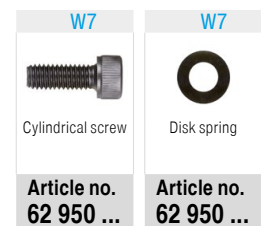



## MicroKom – Filling piece for hi.flex, BluFlex 2

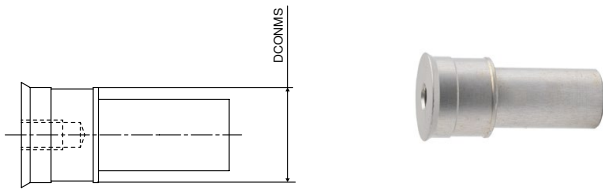

<b>DCONMS</b>	KOMET no.	<b>NEW</b> W4
<b>mm</b>		Article no.
<b>16</b>	M0590501	<b>62 862 ...</b>
		£
		<b>17.66 09300</b>

## Overview of diameters available

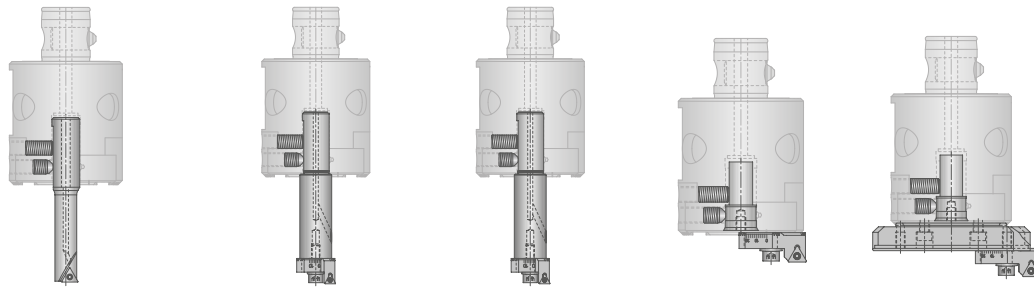

Ø 6–25	Ø 25–44	Ø 44–63	Ø 63–93	Ø 90–125
Boring Bar	Serrated body	Serrated body	Filling piece	Filling piece
62 850 ...	62 861 06300	62 861 06300	62 862 09300	62 862 09300
	+	+	+	+
	Insert holder	Insert holder	Insert holder	Bridge
	62 863 04400	62 863 12500	62 863 12500	62 860 12500
				+
				Insert holder
				62 863 12500

# WOHX

Designation	L	S	D1	IC
	mm	mm	mm	mm
WOHX 02T0..	2.6	1.20	2	4

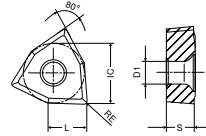

# WOHX

ISO	KOMET no.	RE			
		mm			
02T001	W0004120.018440	0.1			
02T001	W0004120.012710	0.1			
02T001	W0004120.0121	0.1			

	BK2710	BK8440	K10
	<b>F</b>	<b>F</b>	<b>F</b>
	WOHX	WOHX	WOHX
	<b>NEW X2</b>	<b>NEW X2</b>	<b>NEW X2</b>
	Article no. 62 600 ...	Article no. 62 600 ...	Article no. 62 600 ...
	£	£	£
		17.07	
	10102	00102	
			14.03
			20102

Steel	•	•
Stainless steel	•	•
Cast iron	•	
Non ferrous metals		•
Heat resistant alloys		•
Hardened materials		

5

→ v<sub>c</sub> Page 50

# TOGX

Designation	L	S	D1	IC
	mm	mm	mm	mm
TOGX 06T1..	6.64	1.80	2.2	4.0
TOGX 0902..	9.12	2.50	2.8	5.6
TOGX 1403..	13.62	3.00	3.8	8.2

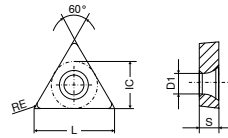

# TOGX

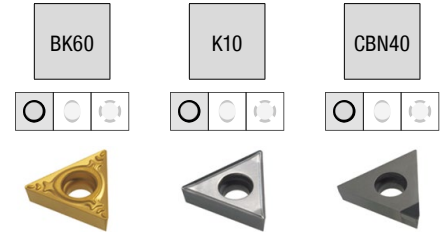

ISO	KOMET no.	RE	BK60		K10		CBN40	
			F	TOGX	F	TOGX	F	TOGX
		mm	NEW X2	Article no.	NEW X2	Article no.	NEW Y0	Article no.
06T102	W5704120.0223	0.2		62 601 ...		62 601 ...		62 601 ...
06T102	W5704140.0260	0.2	£ 13.25	90206	£ 13.25	50206		
06T102	W3004990.0240	0.2					£ 57.04	60206
090204	W5714120.0423	0.4			£ 14.52	50409		
090204	W5714140.0460	0.4	£ 14.52	70409				
090204	W3014990.0440	0.4					£ 63.28	60409
140304	W5726120.0423	0.4			£ 23.45	50414		
140304	W5726140.0460	0.4	£ 20.50	70414				
Steel			●					
Stainless steel								
Cast iron								
Non ferrous metals			●					
Heat resistant alloys			●					
Hardened materials			●					

→ v<sub>c</sub> Page 50

# TOHX

Designation	L	S	D1	IC
	mm	mm	mm	mm
TOHX 06T1..	6.50	1.80	2.2	4.0
TOHX 0902..	9.12	2.50	2.8	5.6
TOHX 1403..	13.62	3.00	3.8	8.2

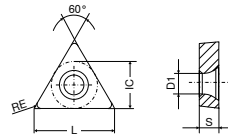

# TOHX

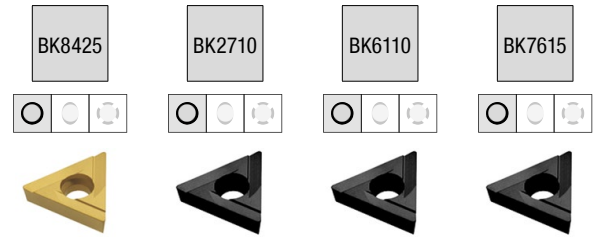

ISO	KOMET no.	RE	BK8425		BK2710		BK6110		BK7615	
			Article no.	Price (£)	Article no.	Price (£)	Article no.	Price (£)	Article no.	Price (£)
06T103	W3004060.032710	0.3	NEW X2 62 602 ...		NEW X2 62 602 ...	13.64	NEW X2 62 602 ...	14.52	NEW X2 62 602 ...	16.09
06T103	W3004060.036110	0.3								
06T103	W3004420.038425	0.3	13.05	30606						
06T103	W3004060.037615	0.3								
090204	W3014060.046110	0.4								
090204	W3014060.042710	0.4			15.51	10409				
090204	W3014060.047615	0.4								
140304	W3026060.046110	0.4						17.95	40414	
Steel			•		•		•	•		•
Stainless steel			•		•		•	•		•
Cast iron			•		•		•	•		•
Non ferrous metals										
Heat resistant alloys										
Hardened materials										

→ v<sub>c</sub> Page 50

# SpinTools – Micro-Boring Head

▲ max. speed 30,000 U/min

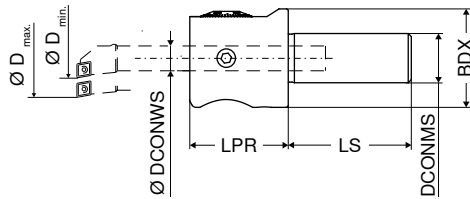

D <sub>min</sub> - D <sub>max</sub> mm	BDX mm	DCONWS mm	DCONMS mm	LPR mm	LS mm	Digital		Analogue	
						W4 Article no. 62 386 ...	W4 Article no. 62 382 ...	W4 Article no. 62 382 ...	W4 Article no. 62 382 ...
0,3 - 7,1	25	4	10	25	25	£ 1,007.23	025	£ 797.43	025
0,3 - 19,1	32	7	16	32	40	£ 1,083.82	032	£ 826.58	032

# SpinTools – Digital Stick

▲ suitable for all SpinTools Digital Heads

**Scope of supply:**

incl. AAA Battery



		W4	
		Article no. 62 309 ...	Article no. 62 309 ...
		£	£
		258.88	000

## Spare parts

for Article no.

	W7 Clamping screw ST		W7 Locking screw			
62 382 025 / 62 386 025	M5x4	£ 1.67	214	M4x8	£ 1.68	228
62 382 032 / 62 386 032	M6x5	£ 1.67	215	M6x10	£ 1.68	229

## SpinTools – Solid carbide boring bar

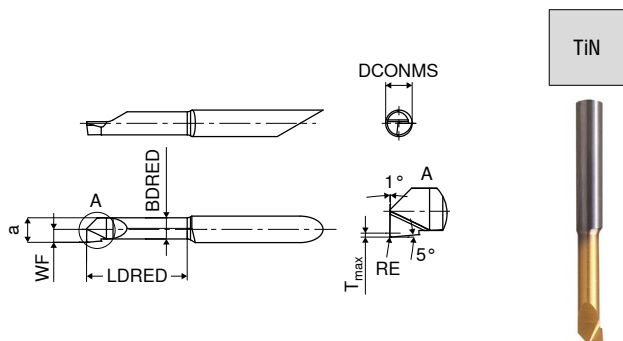

D <sub>min</sub> - D <sub>max</sub> mm	DCONMS mm	LDRED mm	RE mm	a mm	BDRED mm	WF mm	T <sub>max</sub> mm	W4	
								Article no.	£
0,3 - 0,7	4	1.2		0.25	0.15	0.03	0.03	62 383 ...	003
0,6 - 1,1	4	2.5		0.55	0.46	0.30	0.05	35.15	006
1,0 - 2,3	4	4.0	0.05	0.95	0.65	0.50	0.10	35.76	010
2,2 - 3,3	4	6.0	0.05	2.00	1.55	1.10	0.20	29.95	022
3,2 - 4,3	4	10.2	0.05	3.00	2.55	1.60	0.20	30.74	032
3,9 - 7,1	4	15.2	0.05	3.70	3.45	1.95	0.30	33.11	039
5,2 - 6,3	7	20.3	0.05	5.00	4.25	2.60	0.50	46.37	052
6,2 - 7,3	7	20.3	0.05	6.00	5.25	3.10	0.50	46.37	062
6,9 - 12,1	7	25.4	0.20	6.70	6.25	3.45	0.50	41.41	069

Steel	●
Stainless steel	●
Cast iron	●
Non ferrous metals	●
Heat resistant alloys	●
Hardened materials	○

→ v<sub>c</sub> Page 53

## SpinTools – Carbide inserts

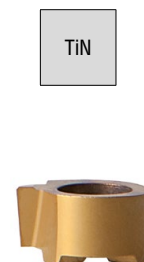
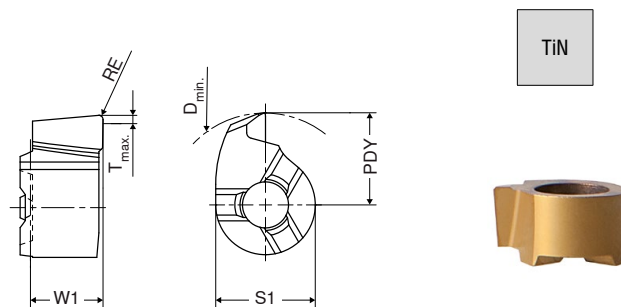

D <sub>min</sub> - D <sub>max</sub> mm	RE mm	PDY mm	S1 mm	W1 mm	T <sub>max</sub> mm	W4	
						Article no.	£
6,9 - 8,1	0.2	3.45	4.8	3.5	1	16.92	069
7,9 - 9,1	0.2	3.95	4.8	3.5	1	16.92	079
8,9 - 10,1	0.2	4.45	4.8	3.5	1	16.92	089
9,9 - 12,1	0.2	4.95	7.0	3.9	1	20.61	099
11,9 - 14,1	0.2	5.95	7.0	3.9	1	20.61	119
13,9 - 19,1	0.2	6.95	7.0	3.9	1	20.61	139

Steel	●
Stainless steel	●
Cast iron	●
Non ferrous metals	●
Heat resistant alloys	●
Hardened materials	○

→ v<sub>c</sub> Page 53

## SpinTools – Adapter

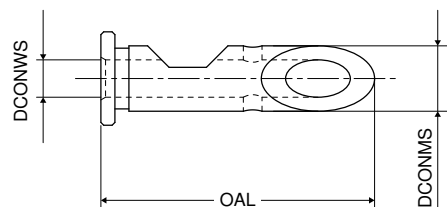

DCONMS	DCONWS	OAL	W4	
mm	mm	mm	Article no.	£
7	4	30	62 335 ...	58.78
			407	

## SpinTools – Toolholder for carbide inserts

- ▲ with thro' coolant
- ▲ appropriate inserts for article no. 62 384 ... can be found in the table above

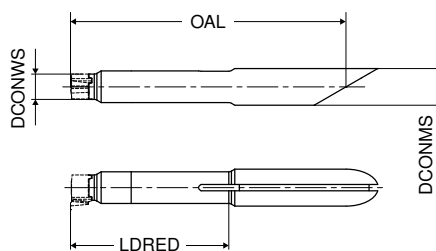

DCONMS	LDRED	DCONWS	OAL	W4	
mm	mm	mm	mm	Article no.	£
7	30	4.8	56	62 385 ...	156.30
7	35	7.0	61		166.91

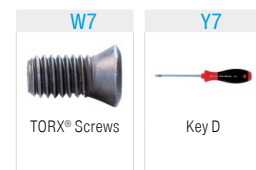

Spare parts		Article no. 62 950 ...		Article no. 80 950 ...	
for Article no.	£	£	007	£	124
62 385 330	9.13	007	13.49	124	
62 385 350	9.13	094	14.77	126	

# SpinTools – Precision boring head

▲ With internal coolant supply

### Scope of supply:

Fine boring head without shank, without insert holder

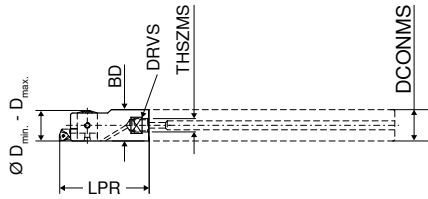

BD	$D_{min} - D_{max}$ mm	THSZMS	DCONMS	LPR	DRVS
mm			mm	mm	mm
14	14,7 - 17,1	M6	14	40	12
16	16,7 - 20,1	M10	16	40	14
19	19,7 - 24,1	M10	18	40	16

W4	
Article no.	62 304 ...
£	694.69
	017
	020
	024

### Spare parts

for Article no.

for Article no.		Article no.	£		Article no.	£		Article no.	£	
62 304 017	M2,5x6	4.42	022	T07	10.30	109	M3x2	2.92	017	
62 304 020	M2,5x6	4.42	022	T07	10.30	109	M3x2,5	2.92	018	
62 304 024	M2,5x6	4.42	022	T07	10.30	109	M3x4	2.92	019	

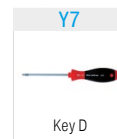

**i** Information on the working length can be found on → Page 55.

# SpinTools – Insert holder, 90°

### Scope of supply:

without insert

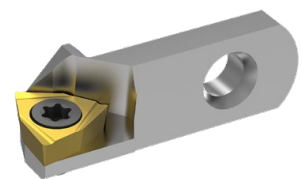
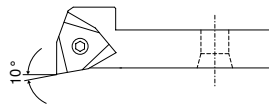

for boring head	Insert
62 304 ...	WC.. 0201..

W4	
Article no.	62 317 ...
£	121.58
	024

**i** Suitable inserts can be found on → Page 47.

### Spare parts

Insert

Insert		Article no.	£		Article no.	£	
WC.. 0201..	M2x3,7	4.42	021	T06	11.15	108	

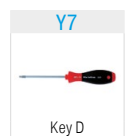

## SpinTools – High-speed carbide boring bars

- ▲ with threaded stud made of high quality steel
- ▲ with thro' coolant
- ▲ Shank clamping length 35 mm
- ▲ Boring shanks with DCONMS  $\varnothing$  18 mm are for use in collet chuck or hydraulic chuck

**Scope of supply:**

boring shank, without boring head

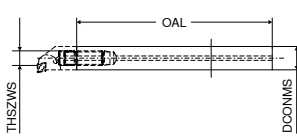

			W4	
DCONMS <sub>h6</sub>	OAL	THSZWS	Article no.	
mm	mm		62 353 ...	
			£	
14	110	M6	296.73	014
16	120	M10	329.84	016
18	100	M10	348.39	018
18	180	M10	622.58	218
18	140	M10	480.85	118

**i** Information on the working length can be found on → Page 55.

## SpinTools – Shank extensions (tempered steel)

- ▲ with thro' coolant

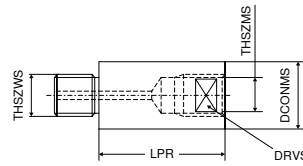

					W4	
DCONMS <sub>h6</sub>	LPR	THSZWS	THSZMS	DRVS	Article no.	
mm	mm			mm	62 349 ...	
					£	
16	32	M10	M10	14	54.78	732
16	64	M10	M10	14	62.78	764

5

## SpinTools – High Speed Steel Extension

- ▲ with thro' coolant
- ▲ Boring shanks with DCONMS  $\varnothing$  18 mm are for use in collet chuck or hydraulic chuck

**Scope of supply:**

boring shank, without boring head

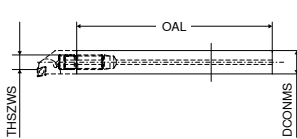

			W4	
DCONMS <sub>h6</sub>	OAL	THSZWS	Article no.	
mm	mm		62 329 ...	
			£	
14	60	M6	69.47	660
16	70	M10	72.14	770
18	80	M10	78.82	880



# SpinTools – Multi-Head – boring and fine boring head

- ▲ For boring bars  $\varnothing$  16 mm and bridges
- ▲ With internal coolant supply
- ▲ LSCX = Boring depth

### Scope of supply:

without boring bar, bridge and insert holder

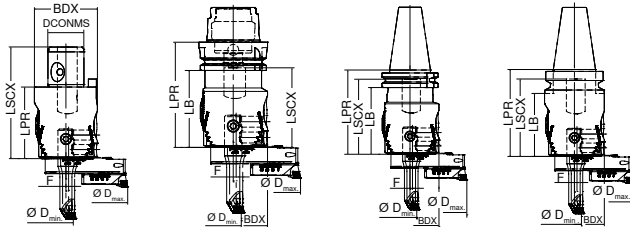

STM Modular

HSK-A 63

SK 40

MAS-BT 40

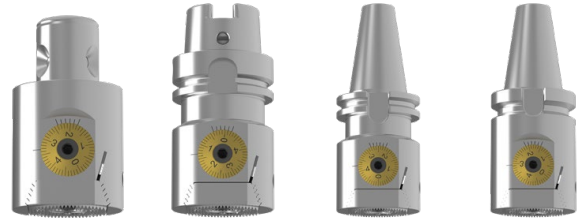

STM Modular

HSK-A

SK

MAS-BT

$D_{min} - D_{max}$ mm	Adapter	DCONMS mm	BDX mm	LPR mm	LB mm	LSCX mm	F mm	STM Modular W4 Article no. 62 372 ... £	HSK-A W4 Article no. 62 373 ... £	SK W4 Article no. 62 373 ... £	MAS-BT W4 Article no. 62 373 ... £	
3 - 320	STM 36	36	63	71.6	70.6	111.6	0 - 2,7	1,001.43	653			
3 - 320	HSK-A 63		63	96.6	70.6	73.0	0 - 2,7		1,225.30	653		
3 - 320	SK 40		63	91.6	72.5	81.6	0 - 2,7			1,225.30	153	
3 - 320	BT 40		63	91.6	69.0	81.6	0 - 2,7				1,225.30	453

**i** Suitable base adapters can be found on → page onwards 40.

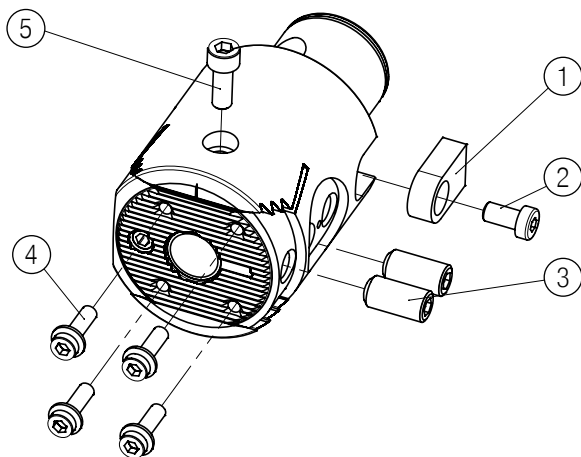

- ① Drive dogs
- ② Carrier screw
- ③ Clamping screw
- ④ Flange screw
- ⑤ Clamping screw MH

### Spare parts

$D_{min} - D_{max}$	16x26,5x8	M6x16	M5x16
3 - 320	Article no. 62 950 ... £ 51.87 040	Article no. 62 950 ... £ 2.74 226	Article no. 62 950 ... £ 4.38 225



### Spare parts

$D_{min} - D_{max}$	M6x16	M6x12
3 - 320	Article no. 62 950 ... £ 1.54 227	Article no. 62 950 ... £ 1.67 167



## SpinTools – Bridge for Multi-Head

- ▲ Ø adjustable
- ▲ With internal coolant supply

### Scope of supply:

- ▲ without tool holder
- ▲ including fixation screws

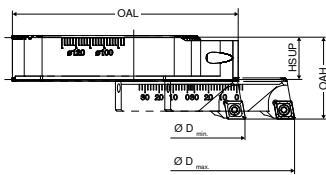

D <sub>min</sub> - D <sub>max</sub> mm	OAL mm	HSUP mm	OAH mm	W4	
				Article no. 62 376 ...	£
86 - 164	80	15	29	231.81	164
162 - 320	158	15	29	347.06	320

**i** Insert holders can be found on → Page 19.

## SpinTools – Axial grooving holder for UltraMini

- ▲ With internal coolant supply

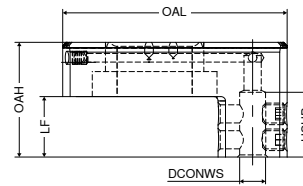

DCONWS	OAL	OAH	HSUP	LF	WT	W4	
						Article no. 62 358 ...	£
6	52	26.58	15	14	0.092	202.67	006
7	52	26.58	15	14	0.091	202.67	007
8	52	26.58	20	14	0.088	202.67	008

**i** Suitable inserts for axial grooving can be found in → Chapter 12, Miniature Turning Tools

## SpinTools – Counterweight

### Scope of supply:

Including fixation screw

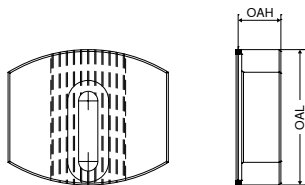

for	OAL	OAH	W4	
			Article no. 62 378 ...	£
62 376 ...	38	12	66.23	320

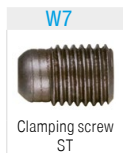

### Spare parts DCONWS

DCONWS	W7	
	Article no. 62 950 ...	£
6	1.67	214
7	1.67	214
8	1.67	214

## SpinTools – Multi-Head – Boring and Fine Boring Head Set

- ▲ suitable for Ø 3 – Ø 320 mm

### Scope of supply:

- ▲ 1 Tool Kit
- ▲ 1 Multi-Head-Boring- and Fine Boring Head (depending on selection)
- ▲ 4 Boring bars
  - 62 345 015 Ø 9.75 - Ø 15.1 mm
  - 62 345 020 Ø 14.75 - Ø 20.1 mm
  - 62 345 024 Ø 19.75 - Ø 25.1 mm
  - 62 345 029 Ø 24.75 - Ø 30.1 mm
- ▲ 2 Boring tools, adjustable
  - 62 375 048 Ø 29.75 - Ø 48.1 mm
  - 62 375 088 Ø 47.75 - Ø 88.1 mm
- ▲ incl. insert holder
  - 62 377 048 CC.. 0602
  - 62 377 088 CC.. 0602
- ▲ 1 Bridge
  - 62 376 164 Ø 86 - Ø 164 mm
- ▲ 1 Torx-Key – T7
- ▲ 1 6-adjustment key – SW5



D <sub>min</sub> - D <sub>max</sub> mm	Adapter	STM Modular W4		HSK-A W4		SK W4		MAS-BT W4	
		Article no. 62 374 ...	£	Article no. 62 379 ...	£	Article no. 62 379 ...	£	Article no. 62 379 ...	£
9,75 - 164	STM 36	1,904.84	999						
9,75 - 164	HSK-A 63			2,120.76	996				
9,75 - 164	SK 40					2,120.76	990		
9,75 - 164	BT 40							2,120.76	993

# SpinTools – Single point boring heads – Modular system

- ▲ LSCX = Boring depth
- ▲ With internal coolant supply

**STM**

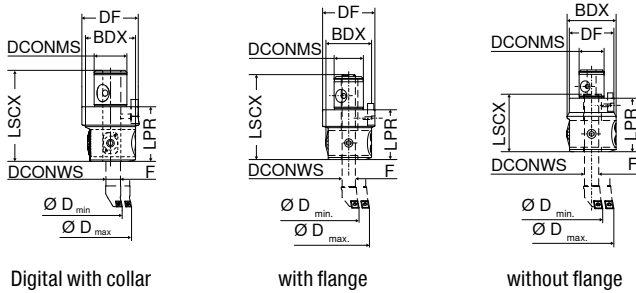

Digital with collar STM Modular	with flange STM Modular	without flange STM Modular
W4	W4	W4
Article no. 62 326 ...	Article no. 62 332 ...	Article no. 62 332 ...
£	£	£
1,075.18	786.89	786.89
036	653	553

D <sub>min</sub> - D <sub>max</sub> mm	Adapter	DCONMS mm	BDX mm	DF mm	DCONWS mm	LPR mm	LSCX mm	WT	
								F mm	kg
3,0 - 88,1	STM 28	28	55	50	16	60	62	0 - 2,7	0.98
3,0 - 88,1	STM 36	36	55	63	16	60	101	0 - 2,7	1.26
3,0 - 88,1	STM 36	36	55	63	16	60	106	0 - 2,7	0.43

## SpinTools – Digital Stick

- ▲ suitable for all SpinTools Digital Heads

**Scope of supply:**  
incl. AAA Battery



W4
Article no. 62 309 ...
£
258.88
000

Spare parts for Article no.	W7 Clamping screw		W7 Screw for drivers		W7 Driver		W7 Clamping screw ST	
	Article no. 62 950 ...	£	Article no. 62 950 ...	£	Article no. 62 950 ...	£	Article no. 62 950 ...	£
62 332 553	M10x16	1.67 047	M5x10	1.67 166	12x20x6	40.84 039	M10x8	1.67 046
62 332 653	M10x16	1.67 047	M6x12	1.67 167	16x26,5x8	51.87 040	M10x8	1.67 046
62 326 036	M10x16	1.67 047	M6x12	1.67 167	16x26,5x8	51.87 040	M10x8	1.67 046

# SpinTools – Single point boring heads

- ▲ Interface for use on ER32 collet chucks
- ▲ LSCX = Recess depth of boring bar
- ▲ with thro' coolant supply
- ▲ Suitable for  $\varnothing$  3.0 -  $\varnothing$  88.1 mm

ER 32

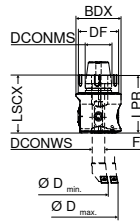

ER 32  
W4

Article no.  
62 332 ...  
£  
983.65 732

$D_{min} - D_{max}$ mm	Adapter	DCONMS mm	BDX mm	DF mm	DCONWS mm	LPR mm	LSCX mm	F mm
3,0 - 88,1	ER 32	32	55	49.5	16	60	86.5	0 - 2,7

5

## Spare parts

for Article no.  
62 332 732



Clamping screw

Article no.  
62 950 ...  
£  
1.67 047



Clamping screw  
ST

Article no.  
62 950 ...  
£  
1.67 046

# SpinTools – Single Point Boring Head – Monoblock

- ▲ LSCX = Boring depth
- ▲ With internal coolant supply

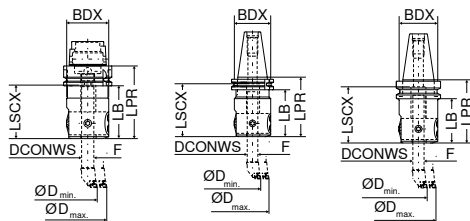

HSK-A 63

SK 40

MAS-BT 40



HSK-A  
W4

Article no.  
62 333 ...  
£  
999.32 653



SK  
W4

Article no.  
62 333 ...  
£  
999.32 153



MAS-BT  
W4

Article no.  
62 333 ...  
£  
999.32 453

$D_{min} - D_{max}$ mm	Adapter	BDX mm	DCONWS mm	LPR mm	LB mm	LSCX mm	F mm	WT kg
3,0 - 88,1	HSK-A 63	55	16	95	69	70	0 - 2,7	1.66
3,0 - 88,1	SK 40	55	16	90	70	80	0 - 2,7	1.83
3,0 - 88,1	BT 40	55	16	90	63	80	0 - 2,7	1.90

## Spare parts

for Article no.  
62 333 653  
62 333 153  
62 333 453



Clamping screw

Article no.  
62 950 ...  
£  
1.67 047



Clamping screw  
ST

Article no.  
62 950 ...  
£  
1.67 046

# SpinTools – Single Point Boring Head – Monoblock

- ▲ LSCX = Boring depth
- ▲ With internal coolant supply

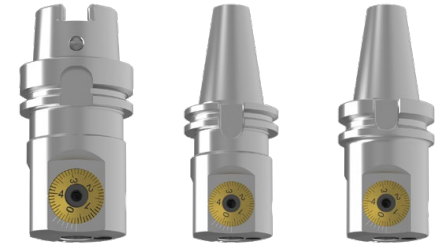
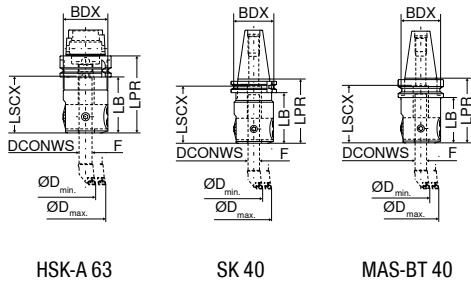

Adapter	BDX	DCONWS	LPR	LB	LSCX	F	Digital HSK-A	Digital SK	Digital MAS-BT
HSK-A 63	55	16	95	70	70	0 - 2,7	Article no. 62 363 ... £ 1,518.14	Article no. 62 363 ... £ 1,518.14	Article no. 62 363 ... £ 1,518.14
SK 40	55	16	90	71	80	0 - 2,7		188	
BT 40	55	16	90	59	80	0 - 2,7			488

# SpinTools – Digital Stick

- ▲ suitable for all SpinTools Digital Heads

Scope of supply:  
incl. AAA Battery



W4
Article no. 62 309 ... £ 258.88
000

## Spare parts

for Article no.  
62 363 488 / 62 363 188

W7	W7
Clamping screw	Clamping screw ST
Article no. 62 950 ... £ 1.67	Article no. 62 950 ... £ 1.67
M10x16 047	M10x8 046

## SpinTools – Boring tools with carbide cutting edge

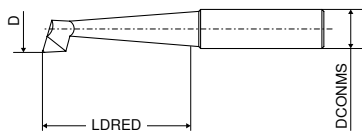

D <sub>min</sub> - D <sub>max</sub> mm	LDRED mm	DCONMS <sub>h6</sub> mm	W4	
			Article no. 62 346 ...	£
3,0 - 8,0	20	10	102.87	008
4,0 - 9,0	23	10	102.87	009
5,0 - 10,0	25	10	102.87	010
6,0 - 11,0	25	10	102.87	011
7,0 - 12,0	31	10	102.87	012

Steel	●
Stainless steel	○
Cast iron	○
Non ferrous metals	●
Heat resistant alloys	○
Hardened materials	○

→ v<sub>c</sub> Page 52

## SpinTools – Adjustable boring bar bridge

▲ With internal coolant supply

Scope of supply:  
without insert holder

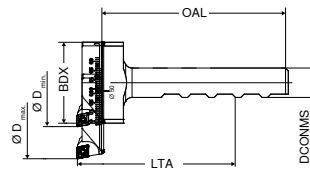

D <sub>min</sub> - D <sub>max</sub> mm	OAL mm	BDX mm	LTA mm	DCONMS mm	W4	
					Article no. 62 375 ...	£
29,75 - 48,1	103	25	85	16	95.37	048
47,75 - 88,1	101	44	85	16	112.22	088

5

## SpinTools – Tool holder for boring bar and bridge Multi-Head

▲ With internal coolant supply

Scope of supply:  
▲ without inserts  
▲ incl. mounting screws

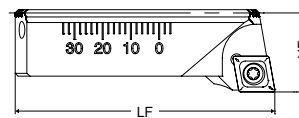

for	LF mm	HF mm	Insert	W4	
				Article no. 62 377 ...	£
62 375 048	28.2	12	CC.. 0602	169.56	048
62 375 088 / 62 376 ...	46.0	14	CC.. 0602	186.77	088
62 375 088 / 62 376 ...	46.0	14	CC.. 09T3	194.72	089

**i** Suitable inserts can be found on → Page 48.

## SpinTools – Steel boring bars

▲ With internal coolant supply

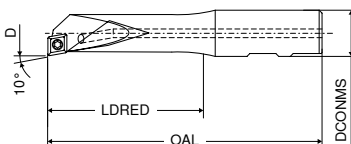

D <sub>min</sub> - D <sub>max</sub> mm	OAL mm	LDRED mm	DCONMS <sub>h6</sub> mm	Insert	W4	
					Article no. 62 345 ...	£
9,75 - 15,1	75	30	16	CC.. 0602	140.27	015
11,75 - 17,1	80	37	16	CC.. 0602	140.27	017
13,75 - 19,1	85	43	16	CC.. 0602	140.27	019
14,75 - 20,1	90	51	16	CC.. 0602	140.27	020
15,75 - 21,1	95	57	16	CC.. 0602	140.27	021
17,75 - 23,1	100	67	16	CC.. 0602	140.27	023
19,75 - 25,1	105	72	16	CC.. 0602	161.65	024
19,75 - 25,1	105	72	16	CC.. 09T3	161.65	025
21,75 - 27,1	110	77	16	CC.. 09T3	161.65	027
24,75 - 30,1	115	82	16	CC.. 0602	161.65	029
24,75 - 30,1	115	82	16	CC.. 09T3	161.65	030
27,75 - 33,1	115	82	16	CC.. 09T3	169.66	033
31,75 - 37,1	115	82	16	CC.. 09T3	169.66	037
34,75 - 40,1	115	82	16	CC.. 09T3	169.66	040
38,75 - 44,1	115	82	16	CC.. 09T3	180.36	044
42,75 - 48,1	115	82	16	CC.. 09T3	189.71	048
47,75 - 53,1	115	82	16	CC.. 09T3	212.43	053

**i** Suitable inserts can be found on → Page 48.

W7		Y7		W7	
TORX® Screws		Key D		Flange screw	
Article no. 62 950 ...		Article no. 80 950 ...		Article no. 62 950 ...	
for Article no.	£	£	£	£	£
62 377 048	4.42	022	10.30	109	4.38
62 377 088	4.42	022	10.30	109	4.38
62 377 089	5.14	023	12.26	113	4.38

## SpinTools – Boring bars with carbide shank

- ▲ With internal coolant supply
- ▲ LTA = max. overhang

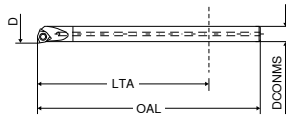

D <sub>min</sub> - D <sub>max</sub> mm	DCONMS <sub>h6</sub> mm	OAL mm	LTA mm	Insert	W4	
					Article no. 62 341 ...	£
5,8 - 11,2	5	80	45	WC.. 0201..	205.75	011
7,8 - 13,2	6	100	60	WC.. 0201..	205.75	013

**i** Suitable inserts can be found on → **Page 47.**

### Spare parts

Insert	Article no.	£	
WC.. 0201..	62 950 ...	4.42	021

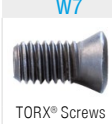
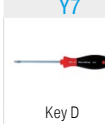
 W7 TORX® Screws Article no. <b>62 950 ...</b> £ 4.42    021	 Y7 Key D Article no. <b>80 950 ...</b> £ 11.15    108
---	---

## SpinTools – Boring tool extensions

- ▲ with thro' coolant

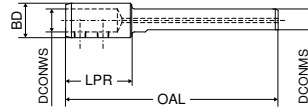

DCONWS	DCONMS	BD	OAL	LPR	W4	
mm	mm	mm	mm	mm	Article no. 62 337 ...	£
10	16	16	128		137.62	128
16	16	24	148	44	156.30	148

W7



Clamping screw

### Spare parts

for Article no.	Article no.	£	
62 337 128	62 950 ...	8.18	048
62 337 148		6.42	049

## SpinTools – Reduction sleeves

- ▲ for boring bars and boring tools

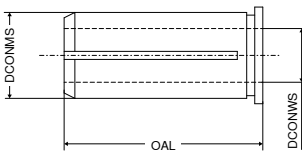

DCONMS	DCONWS	OAL	W4	
mm	mm	mm	Article no. 62 335 ...	£
16	4	37	64.13	104
16	5	37	64.13	105
16	6	37	64.13	106
16	8	37	64.13	108
16	9	37	64.13	109
16	10	37	64.13	110
16	11	37	64.13	111
16	12	37	64.13	112
16	13	37	64.13	113
16	14	37	64.13	114

## SpinTools – High-speed boring head

- ▲ for overturning holder and high speed carbide shank
- ▲ With internal coolant supply
- ▲  $D_{max}$  = using a head with fine adjustment 0 – 2,7 mm

### Scope of supply:

Boring head without boring shank, without inserts

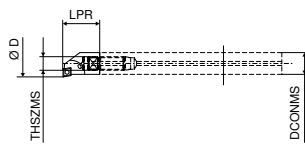

$D_{min} - D_{max}$ mm	LPR mm	THSZMS	DCONMS <sub>h6</sub> mm	Insert	W4	
					Article no. 62 361 ...	£
8,75 - 14,1	18	M5	8	CC.. 0602	96.70	014
9,75 - 15,1	18	M5	9	CC.. 0602	96.70	015
10,75 - 16,1	23	M6	10	CC.. 0602	96.70	016
11,75 - 17,1	23	M6	11	CC.. 0602	96.70	017
12,75 - 18,1	23	M6	12	CC.. 0602	96.70	018
13,75 - 19,1	23	M6	13	CC.. 0602	96.70	019
14,75 - 20,1	23	M6	14	CC.. 0602	96.70	020
15,75 - 21,1	23	M6	14	CC.. 0602	96.70	021
16,75 - 22,1	27	M10	16	CC.. 0602	96.70	022
17,75 - 23,1	27	M10	16	CC.. 0602	96.70	023
19,75 - 25,1	27	M10	16	CC.. 0602	96.70	025
21,75 - 27,1	27	M10	16	CC.. 0602	98.03	027
24,75 - 30,1	27	M10	16	CC.. 0602	98.03	030
27,75 - 33,1	27	M10	16	CC.. 0602	98.03	033
31,75 - 37,1	27	M10	16	CC.. 0602	105.98	037
34,75 - 40,1	27	M10	16	CC.. 0602	113.56	040

**i** Suitable inserts can be found on → Page 48.

## SpinTools – High-speed carbide boring bars

- ▲ with threaded mounting stud made of high quality steel
- ▲ with thro' coolant
- ▲ Shank clamping length 35 mm
- ▲ Boring shanks with DCONMS Ø 18 mm are for use in collet chuck or hydraulic chuck

### Scope of supply:

boring shank, without boring head

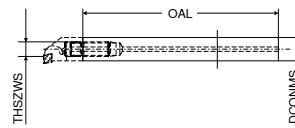

DCONMS <sub>h6</sub> mm	OAL mm	THSZWS	W4	
			Article no. 62 353 ...	£
8	73	M5	194.72	008
9	80	M5	204.01	009
10	82	M6	217.25	010
11	89	M6	227.83	011
12	96	M6	239.75	012
13	103	M6	243.73	013
14	110	M6	296.73	014
16	120	M10	329.84	016

**i** Information on the working length can be found on → Page 55.

## SpinTools – Over turning holder for boring head

- ▲ With internal coolant supply

### Scope of supply:

without boring head and insert

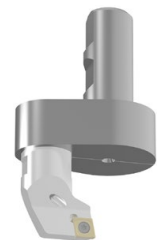
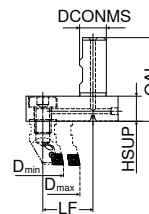

$D_{min} - D_{max}$ mm	DCONMS <sub>h6</sub> mm	LF mm	HSUP mm	OAL mm	W4	
					Article no. 62 404 ...	£
5,3 - 28,6	16	20	15	50	239.75	028
25,3 - 48,6	16	30	15	50	280.82	048

### Spare parts

Insert  
CC.. 0602

W7		Y7	
Article no. 62 950 ...		Article no. 80 950 ...	
£		£	
4.42	022	10.30	109



## Help me choose the correct over-turning adapter

- ▲ for the combination of overturning with high speed boring heads
- ▲ the length L can be extended with shank extensions

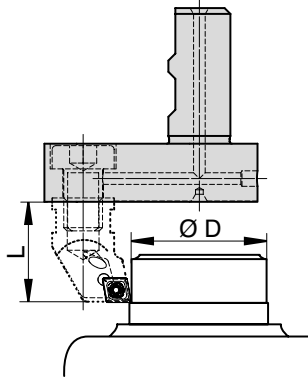

Boring range Ø D <sub>min.</sub> - Ø D <sub>max.</sub> mm	Tool holder 62 404 ...	L mm	Boring Head 62 361 ...	Pages
5,3 - 10,6	028	27	040	23
8,3 - 13,6	028	27	037	
12,3 - 17,6	028	27	033	
15,3 - 20,6	028	27	030	
18,3 - 23,6	028	27	027	
20,3 - 25,6	028	27	025	
22,3 - 27,6	028	27	023	
23,3 - 28,6	028	27	022	
25,3 - 30,6	048	27	040	
28,3 - 33,6	048	27	037	
32,3 - 37,6	048	27	033	
35,3 - 40,6	048	27	030	
38,3 - 43,6	048	27	027	
40,3 - 45,6	048	27	025	
42,3 - 47,6	048	27	023	
43,3 - 48,6	048	27	022	

## SpinTools – Balancing rings

- ▲ For balancing the tools without dynamic balancing machine

### Scope of supply:

CD-ROM with application data and setting values

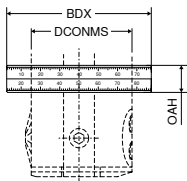

DCONMS	BDX	OAH	WT	W4	
				Article no.	£
mm	mm	mm	kg	62 300 ...	
32	50	16	0.08	223.10	032
40	58	16	0.09	239.14	040
50	70	16	0.13	256.50	050
55	75	16	0.14	265.86	055
63	84	16	0.16	273.88	063

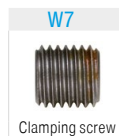

DCONMS	W7	
	Article no.	£
32 - 63	62 950 ...	8.72
		009

### Spare parts

32 - 63

## SpinTools – Single point boring heads Set 1

- ▲ suitable for  $\varnothing 3 - \varnothing 88.1$  mm
- ▲ supplied with  $\varnothing 9.75 - \varnothing 30.1$  or  $\varnothing 9.75 - \varnothing 40.1$  mm
- ▲ with thro' coolant

**Scope of supply:**

- ▲ 1 Tool Kit - 62 345 033  $\varnothing 27.75 - \varnothing 33.1$  mm
- ▲ 1 single point boring head (depending on selection) - 62 345 037  $\varnothing 31.75 - \varnothing 37.1$  mm
- 62 345 040  $\varnothing 34.75 - \varnothing 40.1$  mm
- ▲ 4 Boring bars (SK40- and MAS-BT-Set) ▲ 1 6-adjustment key – SW5
- 62 345 015  $\varnothing 9.75 - \varnothing 15.1$  mm
- 62 345 020  $\varnothing 14.75 - \varnothing 20.1$  mm
- 62 345 024  $\varnothing 19.75 - \varnothing 25.1$  mm
- 62 345 029  $\varnothing 24.75 - \varnothing 30.1$  mm
- ▲ 8 Boring bars (Modular-Set) ▲ 1 Torx-Key – T7
- 62 345 015  $\varnothing 9.75 - \varnothing 15.1$  mm
- 62 345 019  $\varnothing 13.75 - \varnothing 19.1$  mm
- 62 345 023  $\varnothing 17.75 - \varnothing 23.1$  mm
- 62 345 027  $\varnothing 21.75 - \varnothing 27.1$  mm
- 62 345 030  $\varnothing 24.75 - \varnothing 30.1$  mm



D <sub>min</sub> - D <sub>max</sub> mm	Adapter	STM Modular W4		SK W4		MAS-BT W4	
		Article no. 62 334 ...	£	Article no. 62 345 ...	£	Article no. 62 345 ...	£
9,75 - 40,1	STM 36		1,836.96	999			
9,75 - 30,1	SK 40				1,442.86	990	
9,75 - 30,1	BT 40						1,442.86 993

## SpinTools – Single point boring heads Set 2

- ▲ suitable for  $\varnothing 3 - \varnothing 88.1$  mm
- ▲ Supplied with  $\varnothing 9.75 - \varnothing 88.1$  mm
- ▲ with thro' coolant

**Scope of supply:**

- ▲ 1 Tool Kit ▲ 1 Torx key – T7
- ▲ 1 Fine boring head (depending on selection) ▲ 1 6-adjustment key – SW5
- (depending on selection)
- ▲ 4 Boring bars
- 62 345 015  $\varnothing 9.75 - \varnothing 15.1$  mm
- 62 345 020  $\varnothing 14.75 - \varnothing 20.1$  mm
- 62 345 024  $\varnothing 19.75 - \varnothing 25.1$  mm
- 62 345 029  $\varnothing 24.75 - \varnothing 30.1$  mm
- ▲ 2 Boring tools, adjustable
- 62 375 048  $\varnothing 29.75 - \varnothing 48.1$  mm
- 62 375 088  $\varnothing 47.75 - \varnothing 88.1$  mm
- ▲ incl. insert holder
- 62 377 048 CC.. 0602
- 62 377 088 CC.. 0602



D <sub>min</sub> - D <sub>max</sub> mm	Adapter	STM Modular W4		HSK-A W4		SK W4		MAS-BT W4	
		Article no. 62 334 ...	£	Article no. 62 345 ...	£	Article no. 62 345 ...	£	Article no. 62 345 ...	£
9,75 - 88,1	STM 36		1,750.12	997					
9,75 - 88,1	HSK-A 63				1,962.54	997			
9,75 - 88,1	SK 40					1,962.54	998		
9,75 - 88,1	BT 40							1,962.54	999

## SpinTools – Single point boring heads ER32 Set

- ▲ Suitable for  $\varnothing$  3.0 -  $\varnothing$  88.1 mm
- ▲ Scope of supply  $\varnothing$  9.75 -  $\varnothing$  30.1 mm
- ▲ with thro' coolant supply

### Scope of supply:

- ▲ 1 tool kit
- ▲ 1 single point boring head (62332732)
- ▲ 4 boring bars
  - 62 345 015  $\varnothing$  9.75 -  $\varnothing$  15.1 mm
  - 62 345 020  $\varnothing$  14.75 -  $\varnothing$  20.1 mm
  - 62 345 024  $\varnothing$  19.75 -  $\varnothing$  25.1 mm
  - 62 345 029  $\varnothing$  24.75 -  $\varnothing$  30.1 mm
- ▲ 1 Torx Key – T7
- ▲ 1 Allen Key – SW5



$D_{min} - D_{max}$ mm	Adapter	W4 Article no. 62 332 ... £ 1,309.45	999
9,75 - 30,1	ER 32		

# SpinTools – Single point finish boring heads

▲ With internal coolant supply

**Scope of supply:**

without insert holder and inserts

**STM**

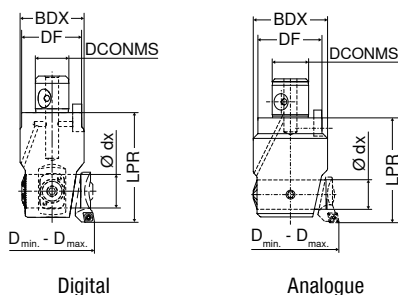

5

D <sub>min</sub> - D <sub>max</sub> mm	D <sub>min</sub> - D <sub>max</sub> extended mm	Adapter	DCONMS mm	BDX mm	DF mm	LPR mm	Ø dx mm	WT kg	Digital STM Modular W4		Analogue STM Modular W4	
									Article no. 62 308 ...	Article no. 62 303 ...	Article no. 62 303 ...	Article no. 62 303 ...
23,9 - 31,1	29,9 - 37,1	STM 11	11	20	20	40	11	0.08	770.83	031	513.01	031
30,9 - 40,1	37,9 - 47,1	STM 14	14	25	25	45	13	0.15	770.83	040	513.01	040
39,9 - 51,1	47,9 - 59,1	STM 18	18	32	32	65	17	0.38	789.47	051	530.38	051
50,9 - 67,1	64,9 - 81,1	STM 22	22	42	40	72	22	0.70	817.47	067	555.76	067
66,9 - 87,1	84,9 - 105,1	STM 28	28	55	50	82	30	1.32	865.28	087	599.86	087
86,9 - 116,1	104,9 - 134,1 (124,9 - 154,1)	STM 36	36	72	63	105	30	3.15	979.56	116	701.39	116

**i** For optimal stability when fine boring the main insert holder ranges are preferred over the extended range.

# SpinTools – Digital Stick

▲ suitable for all SpinTools Digital Heads

**Scope of supply:**

incl. AAA Battery



W4
Article no. 62 309 ...
£ 258.88
000

Spare parts for Article no.	W7		W7		W7		W7	
	Article no. 62 950 ...	Article no. 62 950 ...	Article no. 62 950 ...	Article no. 62 950 ...	Article no. 62 950 ...	Article no. 62 950 ...	Article no. 62 950 ...	
	£	£	£	£	£	£	£	
62 303 031 / 62 308 031	M2x2,5	1.12 162	5x8,5x3	26.93 035	M4x6	8.72 287	M4x3	1.67 213
62 303 040 / 62 308 040	M2,5x6	1.12 163	6x10,3x4	28.78 036	M5x8	8.72 288	M5x4	1.67 214
62 303 051 / 62 308 051	M3x8	1.38 164	8x15x5	30.22 037	M6x10	8.72 289	M6x5	1.67 215
62 303 067 / 62 308 067	M4x10	1.38 165	10x18,1x6	34.09 038	M8x12	8.72 290	M8x6	1.67 216
62 303 087 / 62 308 087	M5x10	1.67 166	12x20x6	40.84 039	M10x16	8.72 291	M10x10	1.67 217
62 303 116 / 62 308 116	M6x12	1.67 167	16x26,5x8	51.87 040	M10x16	8.72 291	M10x18	1.67 218

## SpinTools – High-speed carbide boring tools

- ▲ for single point finish boring heads Article no. 62 303 ..., 62 308 ...
- ▲ with thro' coolant

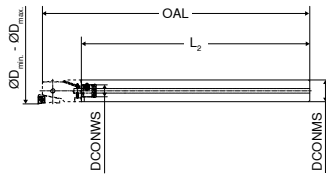

D <sub>min</sub> - D <sub>max</sub> mm	DCONWS mm	DCONMS <sub>h5</sub> mm	OAL mm	L <sub>2</sub> mm	WT kg	W4	
						Article no. 62 354 ...	£
23,9 - 31,1	11	20	250	210	0.81	1,061.03	020
30,9 - 40,1	14	25	306	261	1.54	1,450.49	025
39,9 - 51,1	18	32	380	315	3.03	2,270.45	032

## SpinTools – Insert holder, 90° and 95°

- ▲ for single point finish boring heads Article no. 62 303 ..., 62 308 ...

### Scope of supply:

incl. Torx clamping screw for inserts, without fixing bolt for holder

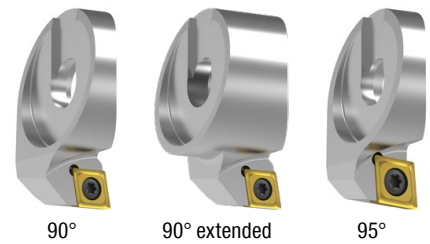
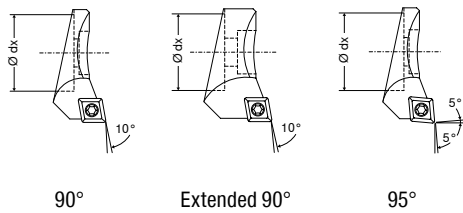

Ø dx mm	Insert	W4		W4		W4	
		Article no. 62 318 ...	£	Article no. 62 318 ...	£	Article no. 62 320 ...	£
11	CC.. 0602	106.88	031	126.91	037	117.57	031
13	CC.. 0602	117.57	040	140.27	047	129.59	040
17	CC.. 0602	129.59	051	153.63	059	142.94	051
22	CC.. 0602	140.27	067	167.00	081	146.95	067
30	CC.. 0602	152.30	087	180.36	105		
30	CC.. 09T3	152.30	116	180.36	134	167.00	087
30	CC.. 09T3			211.08	154		

**i** Suitable inserts can be found on → **Page 48.**

### Spare parts

Insert		W7		Y7		
		Article no. 62 950 ...	£	Article no. 80 950 ...	£	
CC.. 0602	M2,5x6	4.42	022	T07	10.30	109
CC.. 09T3	M4x9	5.14	023	T15	12.26	113

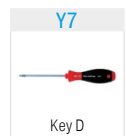

# SpinTools – Reverse adapter for back boring

▲ For insert holder article no. 62 318 ... / 62 320 ...

### Scope of supply:

Adapter including fixing bolt

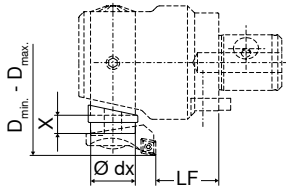

				W4	
				Article no. 62 321 ...	
X	Ø dx	LF	Ø D <sub>min</sub> - D <sub>max</sub>	£	
mm	mm	mm	mm		
6.5	11	13.0	37 - 44	165.66	044
8.0	11	13.0	40 - 47	165.66	051
6.5	13	12.6	44 - 53	165.66	053
10.0	13	12.6	51 - 60	165.66	060
6.5	17	31.3	53 - 64	165.66	064
10.0	17	31.3	60 - 71	165.66	071
6.5	22	31.2	68 - 80	171.01	080
12.0	22	31.2	75 - 91	171.01	091
10.0	30	29.0	87 - 107	176.33	107

**i** Note left hand direction of spindle rotation when in use

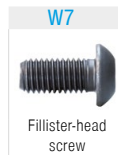

Article no. 62 950 ...

Spare parts		W7	
for Article no.		Article no. 62 950 ...	
		£	
62 321 044		8.68	278
62 321 051		8.98	279
62 321 053		8.68	280
62 321 060		8.98	281
62 321 064		8.68	282
62 321 071		8.98	283
62 321 080		8.68	284
62 321 091		8.98	285
62 321 107		10.28	286

# Minimum diameter (Ø B) during retraction for back boring

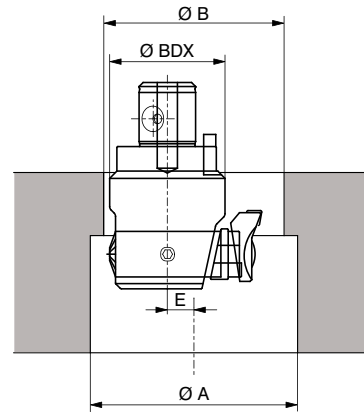

Minimum diameter (Ø B) of the entry bore

$$\text{Ø B} = \frac{\text{Ø BDX} + \text{Ø A}}{2} + 1^*$$

Minimum offset (E) for starting

$$E = \frac{\text{Ø A} - \text{Ø B}}{2} + 0,5^*$$

\*Safety margin

Example:  
Boring head = 62 303 031  
Insert Holder = 62 318 031  
Reverse adapter = 62 321 044  
Ø BDX = 20 mm  
Ø A ≙ Amin. = 37 mm  
\*Safety margin = 1 mm

$$\text{Ø B} = \frac{20 + 37}{2} = 28,5 + 1 = 29,5 \text{ mm}$$

## SpinTools – Vario-Head – boring and fine boring head

- ▲ For boring bars with a diameter of 16 mm and insert holders
- ▲ with thro' coolant supply
- ▲ LSCX = Recess depth of boring bar

**Scope of supply:**

Without boring bar and insert holder  
Incl. coolant insert

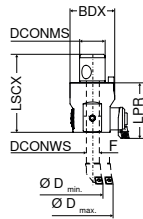

Digital  
STM Modular  
W4  
Article no.  
62 364 ...  
£  
1,191.59 101

D <sub>min</sub> - D <sub>max</sub> mm	Adapter	DCONMS mm	BDX mm	DCONWS mm	LPR mm	LSCX mm	F mm
3 - 125	STM 36	36	63	16	76.5	110	0 - 6,5

## SpinTools – Digital Stick

- ▲ suitable for all SpinTools Digital Heads

**Scope of supply:**

incl. AAA Battery



W4  
Article no.  
62 309 ...  
£  
258.88 000

**Spare parts**

for Article no.  
62 364 101

W4	W7	W7
Coolant insert	Clamping screw VH	Grubscrew
Article no. 62 366 ... £ 85.10 002	Article no. 62 950 ... £ 5.41 341	Article no. 62 950 ... £ 5.41 340
M10X12	M5X16	

**Spare parts**

for Article no.  
62 364 101

W7	W7
Cylindrical screw	Clamping screw
Article no. 62 950 ... £ 6.49 343	Article no. 62 950 ... £ 5.41 342
M10x25	M10X18

## SpinTools – Insert holder, 90°

▲ for Vario-Head boring and fine boring head 62 364 101

### Scope of supply:

incl. Torx clamping screw for inserts, without fixing bolt for holder

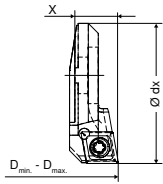

## SpinTools – Spacer

▲ For insert holder article no. 62 365 ...

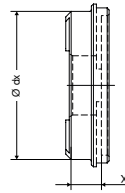

X mm	Ø dx mm	Insert	Ø D <sub>min</sub> - D <sub>max</sub> mm	D <sub>min</sub> - D <sub>max</sub> extended mm	90°	
					Article no.	Price
					W4	
					Article no.	
					62 365 ...	
					£	
13.05	30	CC.. 09T3	87,75 - 101,1	101,1 - 105,75	188.80	101
22.05	30	CC.. 09T3	105,75 - 119,1	119,1 - 125,75	225.46	119
32.05	30	CC.. 09T3	125,75 - 139,1	139,1 - 152	264.06	139

X mm	Ø dx mm	Article no.	Price
6.5	30	62 366 ...	
		£	
		215.18	001

5

## SpinTools – Vario Digital single point boring head (set)

- ▲ Suitable for Ø 3 - Ø 152 mm
- ▲ supplied with Ø 9.75 - Ø 101.1 mm
- ▲ with thro' coolant supply

### Scope of supply:

- ▲ 1 tool kit
- ▲ 1 single point finish boring head
  - 62 364 101
- ▲ 2 boring bars
  - 62 345 015 Ø 9.75 - Ø 20.1 mm
  - 62 345 024 Ø 19.75 - Ø 30.1 mm
- ▲ Boring bars, adjustable
  - 62 375 048 Ø 29.75 - Ø 48.1 mm
  - 62 377 088 Ø 47.75 - Ø 88.1 mm
- ▲ 3 insert holders
  - 62 377 048 Ø 29.75 - Ø 48.1 mm
  - 62 375 088 Ø 47.75 - Ø 88.1 mm
  - 62 365 101 Ø 87.75 - Ø 101.1 mm
- ▲ 1 coolant insert 62 366 002
- ▲ 1 digital display unit 62 309 000
- ▲ 4 Allen keys – SW2.5/4/5/8
- ▲ 2 Torx keys – T7/15



D <sub>min</sub> - D <sub>max</sub> mm	Adapter	Article no.	Price
9,75 - 101,1	STM 36	62 364 ...	
		£	
		2,226.38	999

STM Modular  
W4



## SpinTools – Single point finish boring heads

- ▲ With internal coolant supply
- ▲ extremely stable connection between insert holder and boring head

**Scope of supply:**

Boring head, without insert holder, pressure plate and support

**STM**

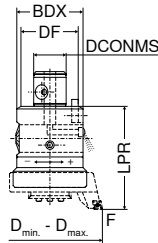

STM Modular  
W4

$D_{min} - D_{max}$ mm	Adapter	DCONMS mm	BDX mm	DF mm	LPR mm	F mm	WT kg	Article no. 62 305 ...	£	302
86 - 402	STM 36	36	72	63	120	± 1,25	2.94		1,557.74	

Spare parts		W7		W7		W7		W7	
for Article no. 62 305 302		Cylindrical screw Article no. 62 950 ... £ 5.00 292		Screw for drivers Article no. 62 950 ... £ 1.67 167		Driver Article no. 62 950 ... £ 51.87 040		Clamping screw ST Article no. 62 950 ... £ 8.98 011	
	M8x45		M6x12		16x26,5x8		M8x60		

## SpinTools – Tool holder

- ▲ for single point finish boring heads
- ▲ Approach angle 90°

**Scope of supply:**



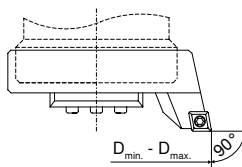

incl. cover plate and support



$\emptyset D_{min} - D_{max}$ mm	Insert	Article no. 62 438 ...	£	W4
86 - 138	CC.. 09T3		335.15	138
86 - 138	CC.. 1204		335.15	238
136 - 220	CC.. 09T3		400.04	220
136 - 220	CC.. 1204		398.72	320
188 - 302	CC.. 09T3		499.39	302
242 - 402	CC.. 09T3		598.73	402

**i** Suitable inserts can be found on → Page 48.

## Spare parts – insert holder

		W7  TORX® Screws		Y7  Key D		W7  Pressure plate		W7  Support		
Spare parts		Article no. 62 950 ...		Article no. 80 950 ...		Article no. 62 950 ...		Article no. 62 950 ...		
for Article no.		£	023	£	113	£	152	£	149	
62 438 138	M4x9	5.14	023	T15	12.26	113	91.51	152	69.16	149
62 438 238	M5x10	5.84	232	T20	13.11	114	91.51	152	69.16	149
62 438 220	M4x9	5.14	023	T15	12.26	113	105.18	153	78.15	150
62 438 320	M5x10	5.84	232	T20	13.11	114	105.18	153	78.15	150
62 438 302	M4x9	5.14	023	T15	12.26	113	105.18	153	78.15	150
62 438 402	M4x9	5.14	023	T15	12.26	113	105.18	153	78.15	150

## SpinTools – Boring set

- ▲ suitable for Ø 86 – Ø 402 mm
- ▲ supplied with Ø 86 – Ø 302 mm
- ▲ with thro' coolant

### Scope of supply:

- ▲ 1 Case
- ▲ 1 single point finish boring head
  - 62 305 302
- ▲ 3 insert holders
  - 62 438 138 Ø 86 – Ø 138 mm
  - 62 438 220 Ø 136 – Ø 220 mm
  - 62 438 302 Ø 188 – Ø 302 mm
- ▲ 2 pressure plates and 2 supports
  - 62 950 149
  - 62 950 150
  - 62 950 152
  - 62 950 153
- ▲ 1 Allen Key – SW5
- ▲ 1 Torx Key – T15



D <sub>min</sub> - D <sub>max</sub> mm	Adapter	STM Modular W4 Article no. 62 439 ...	£	999
86 - 302	STM 36		2,398.94	

# SpinTools – Twin edged Rough / Finish Boring Head

- ▲ Adjustable tools with through coolant
- ▲ each line on the adjustment scale equivalent to 0.01 mm on diameter

### Scope of supply:

Boring head with spindle adjustment, carrier, stop pin, 2 screws, 2 lock washers

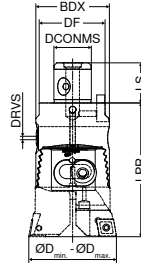

D <sub>min</sub> - D <sub>max</sub> mm	Adapter	DCONMS mm	BDX mm	DF mm	LPR mm	LS mm	DRVS mm	WT kg	STM Modular W4	
									Article no. 62 380 ...	£
29,5 - 40,1	STM 14	14	25	25	55	16	2.5	0.12	398.72	040
39,5 - 50,5	STM 18	18	32	32	65	20	2.5	0.24	415.94	050
49,5 - 66,5	STM 22	22	42	40	82	24	3.0	0.48	450.39	066
65,5 - 87,5	STM 28	28	55	50	100	30	3.0	0.94	500.72	087
86,5 - 115,5	STM 36	36	72	63	125	40	3.0	1.89	601.40	115

### Spare parts

for Article no.

for Article no.		W7		W7		W7	
		Article no. 62 950 ...	£	Article no. 62 950 ...	£	Article no. 62 950 ...	£
62 380 040	M5x12	293	3.29	Ø 5,3/9,3	312	1.12	8.68
62 380 050	M6x16	294	3.29	Ø 6.4/10,2	313	1.12	8.68
62 380 066	M8x20	295	3.29	Ø 8,4/14,0	314	1.12	9.74
62 380 087	M10x25	296	3.41	Ø 10,5/17,0	315	1.12	9.74
62 380 115	M12x25	297	3.71	Ø 13,0/21,0	316	1.12	9.74

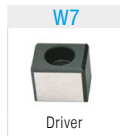
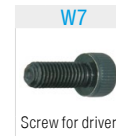
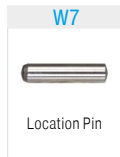
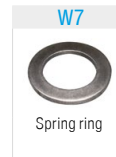
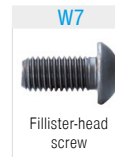

### Spare parts

for Article no.

for Article no.		W7		W7		
		Article no. 62 950 ...	£	Article no. 62 950 ...	£	
62 380 040	M2,5x6	163	1.12	6x10,3x4	036	28.78
62 380 050	M3x8	164	1.38	8x15x5	037	30.22
62 380 066	M4x10	165	1.38	10x18,1x6	038	34.09
62 380 087	M5x10	166	1.67	12x20x6	039	40.84
62 380 115	M6x12	167	1.67	16x26,5x8	040	51.87

## SpinTools – Pair of Roughing / Finishing Insert Holders, 90°

- ▲ the insert holder for the finishing process is set back axially by 0.4 mm
- ▲ the insert holder for the finishing process is moved by the adjustable spindle
- ▲ the finishing insert must be mounted in the holder without radial adjustment screw
- ▲ machining allowance for the finishing insert holder approximately 0.3 mm in diameter

### Scope of supply:

pair of insert holders, 1 adjusting screw, 2 WSP-clamping screws, 1 Grub screw

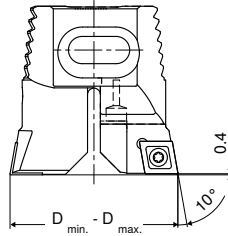

5

Ø D <sub>min</sub> - D <sub>max</sub> mm	Insert	W4	
		Article no. 62 381 ...	£
29,5 - 40,1	CC.. 0602	305.99	040
39,5 - 50,5	CC.. 09T3	325.86	050
49,5 - 66,5	CC.. 09T3	372.23	066
65,5 - 87,5	CC.. 1204	484.82	087
86,5 - 115,5	CC.. 1204	755.05	115

**i** Suitable inserts can be found on → **Page 48.**

Spare parts for Article no.	W7 TORX® Screws		Y7 Key D		W7 Adjustment screw		W7 Adjustment screw					
	Article no. 62 950 ...	£	Article no. 80 950 ...	£	Article no. 62 950 ...	£	Article no. 62 950 ...	£				
62 381 040	M2,5x6	4.42	022	T07	10.30	109	M3x8 - SW1,5	5.34	015	M4x0,5x9,5	6.98	239
62 381 050	M4x9	5.14	023	T15	12.26	113	M3x8 - SW1,5	5.34	015	M4x0,5x13	7.26	240
62 381 066	M4x9	5.14	023	T15	12.26	113	M3x8 - SW1,5	5.34	015	M6x14	1.67	241
62 381 087	M5x10	5.84	232	T20	13.11	114	M3x8 - SW1,5	5.34	015	M6x20	1.67	242
62 381 115	M5x10	5.84	232	T20	13.11	114	M3x8 - SW1,5	5.34	015	M6x30	1.99	333

# SpinTools – Boring heads for roughing with 2 cutting edges

▲ With internal coolant supply

## Scope of supply:

Boring head, Drive dogs, Mounting screws and Spring rings

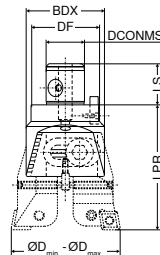

D <sub>min</sub> - D <sub>max</sub> mm	Adapter	DCONMS mm	BDX mm	DF mm	LPR mm	LS mm	WT kg	STM Modular W4	
								Article no. 62 295 ...	£
23,5 - 30,5	STM 11	11	20	20	40	13	0.05	223.10	030
29,5 - 40,1	STM 14	14	25	25	45	16	0.09	239.14	040
39,5 - 50,5	STM 18	18	32	32	65	20	0.25	256.50	050
49,5 - 66,5	STM 22	22	42	40	72	24	0.38	291.25	066
65,5 - 87,5	STM 28	28	55	50	82	30	0.59	342.01	087
86,5 - 115,5	STM 36	36	72	63	105	40	1.23	444.87	115
114,5 - 153,0	STM 36	36	94	94	140	40	2.80	770.85	153

## Spare parts

for Article no.

for Article no.	Article no. 62 950 ...	£	Article no. 62 950 ...	£	Article no. 62 950 ...	£
62 295 030	M4x8	3.29 298	Ø 4,3/7,3	1.12 311	8.68 231	
62 295 040	M5x12	3.29 293	Ø 5,3/9,3	1.12 312	8.68 231	
62 295 050	M6x16	3.29 294	Ø 6,4/10,2	1.12 313	8.68 231	
62 295 066	M8x20	3.29 295	Ø 8,4/14,0	1.12 314	9.74 234	
62 295 087	M10x25	3.41 296	Ø 10,5/17,0	1.12 315	9.74 234	
62 295 115	M12x25	3.71 297	Ø 13,0/21,0	1.12 316	9.74 234	
62 295 153	M16x35	10.18 299	Ø 17,0/34,0	1.71 317	9.74 234	

## Spare parts

for Article no.

for Article no.	Article no. 62 950 ...	£	Article no. 62 950 ...	£
62 295 030	M2x2,5	1.12 162	5x8,5x3	26.93 035
62 295 040	M2,5x6	1.12 163	6x10,3x4	28.78 036
62 295 050	M3x8	1.38 164	8x15x5	30.22 037
62 295 066	M4x10	1.38 165	10x18,1x6	34.09 038
62 295 087	M5x10	1.67 166	12x20x6	40.84 039
62 295 115	M6x12	1.67 167	16x26,5x8	51.87 040
62 295 153	M6x12	1.67 167	16x26,5x8	51.87 040

## SpinTools – Pair of tool holders, standard, 90°

### Scope of supply:

Adjustment screws, positioning pin, insert clamping screws

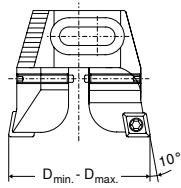

## SpinTools – Pair of tool holders, standard, 70°

### Scope of supply:

Adjustment screws, positioning pin, insert clamping screws

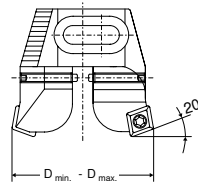

Ø D <sub>min</sub> - D <sub>max</sub> mm	Insert	W4	
		Article no. 62 296 ...	£
23,5 - 30,5	CC.. 0602	256.50	030
29,5 - 40,1	CC.. 0602	268.53	040
39,5 - 50,5	CC.. 09T3	287.24	050
49,5 - 66,5	CC.. 09T3	327.32	066
65,5 - 87,5	CC.. 1204	408.80	087
65,5 - 87,5	CN.. 1204	426.18	088
86,5 - 115,5	CC.. 1204	646.61	115
86,5 - 115,5	CN.. 1606	665.31	116
114,5 - 153	CC.. 1204	780.21	153
114,5 - 153	CN.. 1606	847.01	154

Ø D <sub>min</sub> - D <sub>max</sub> mm	Insert	W4	
		Article no. 62 299 ...	£
23,5 - 30,5	CC.. 0602	256.50	030
29,5 - 40,1	CC.. 0602	268.53	040
39,5 - 50,5	CC.. 09T3	287.24	050
49,5 - 66,5	CC.. 09T3	327.32	066
65,5 - 87,5	CC.. 1204	408.80	087
65,5 - 87,5	CN.. 1204	426.18	088
86,5 - 115,5	CC.. 1204	646.61	115
86,5 - 115,5	CN.. 1606	665.31	116
114,5 - 153	CN.. 1606	847.01	154

**i** Suitable inserts can be found on → Page 48.

### Spare parts

Ø D <sub>min</sub> - D <sub>max</sub>	Insert	W7		Y7		W7				
		Article no. 62 950 ...	£	Article no. 80 950 ...	£	Article no. 62 950 ...	£			
114,5 - 153	CC.. 1204	M5x10	5.84	232	T20	13.11	114	M6x40	3.32	335
23,5 - 30,5	CC.. 0602	M2,5x6	4.42	022	T07	10.30	109	M4x0,5x7	6.84	238
29,5 - 40,1	CC.. 0602	M2,5x6	4.42	022	T07	10.30	109	M4x0,5x9,5	6.98	239
39,5 - 50,5	CC.. 09T3	M4x9	5.14	023	T15	12.26	113	M4x0,5x13	7.26	240
49,5 - 66,5	CC.. 09T3	M4x9	5.14	023	T15	12.26	113	M6x14	1.67	241
65,5 - 87,5	CC.. 1204	M5x10	5.84	232	T20	13.11	114	M6x20	1.67	242
86,5 - 115,5	CC.. 1204	M5x10	5.84	232	T20	13.11	114	M6x30	1.99	333

### Spare parts

Ø D <sub>min</sub> - D <sub>max</sub>	Insert	W7		W7		W7		W7		W7		
		Article no. 62 950 ...	£	Article no. 62 950 ...	£	Article no. 62 950 ...	£	Article no. 62 950 ...	£	Article no. 62 950 ...	£	
114,5 - 153	CN.. 1606	2.29	177	7.56	180	23.66	179	24.95	178	M8x40	2.29	334
65,5 - 87,5	CN.. 1204	2.29	096	7.56	136	21.36	125	18.25	117	M6x20	1.67	242
86,5 - 115,5	CN.. 1606	2.29	177	7.56	180	23.66	179	24.95	178	M6x30	1.99	333

## SpinTools – Pair of tool holders, ‘Synchro’, 90°

### Scope of supply:

Insert clamping screws, synchronization screw

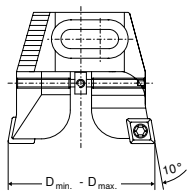

## SpinTools – Tool holder 90°, axial offset 0.4 mm

### Scope of supply:

2 adjustment screws, 1 positioning pin, insert clamping screw

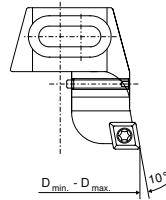

Ø D <sub>min</sub> - D <sub>max</sub> mm	Insert	W4	
		Article no. 62 297 ...	£
23,5 - 30,5	CC.. 0602	295.25	030
29,5 - 40,1	CC.. 0602	308.60	040
39,5 - 50,5	CC.. 09T3	328.64	050
49,5 - 66,5	CC.. 09T3	375.41	066
65,5 - 87,5	CC.. 1204	488.97	087
86,5 - 115,5	CC.. 1204	761.50	115
114,5 - 153	CC.. 1204	911.12	153

Ø D <sub>min</sub> - D <sub>max</sub> mm	Insert	W4	
		Article no. 62 298 ...	£
23,5 - 30,5	CC.. 0602	171.01	030
29,5 - 40,1	CC.. 0602	179.02	040
39,5 - 50,5	CC.. 09T3	192.38	050
49,5 - 66,5	CC.. 09T3	219.10	066
65,5 - 87,5	CC.. 1204	285.89	087
86,5 - 115,5	CC.. 1204	443.54	115
114,5 - 153	CC.. 1204	533.06	153

**i** Suitable inserts can be found on → Page 48.

Spare parts for Article no.	W7 TORX® Screws		W7 Synchronization screw		Y7 Key D		W7 Adjustment screw					
	Article no. 62 950 ...	£	Article no. 62 950 ...	£	Article no. 80 950 ...	£	Article no. 62 950 ...	£				
62 297 030	M2,5x6	4.42	022	M4x0,5x18	50.99	207	T07	10.30	109	M4x0,5x7	6.84	238
62 297 040	M2,5x6	4.42	022	M4x0,5x23	51.17	208	T07	10.30	109	M4x0,5x9,5	6.98	239
62 297 050	M4x9	5.14	023	M4x0,5x30	52.87	209	T15	12.26	113	M4x0,5x13	7.26	240
62 297 066	M4x9	5.14	023	M6x40	54.18	210	T15	12.26	113	M6x14	1.67	241
62 297 087	M5x10	5.84	232	M6x52	55.64	211	T20	13.11	114	M6x20	1.67	242
62 297 115	M5x10	5.84	232	M6x68	57.25	212	T20	13.11	114	M6x30	1.99	333
62 297 153	M5x10	5.84	232	M6x90	88.55	220	T20	13.11	114	M6x40	3.32	335

Spare parts for Article no.	W7 TORX® Screws		W7 Synchronization screw		Y7 Key D		W7 Adjustment screw					
	Article no. 62 950 ...	£	Article no. 62 950 ...	£	Article no. 80 950 ...	£	Article no. 62 950 ...	£				
62 298 030	M2,5x6	4.42	022	M4x0,5x18	50.99	207	T07	10.30	109	M4x0,5x7	6.84	238
62 298 040	M2,5x6	4.42	022	M4x0,5x23	51.17	208	T07	10.30	109	M4x0,5x9,5	6.98	239
62 298 050	M4x9	5.14	023	M4x0,5x30	52.87	209	T15	12.26	113	M4x0,5x13	7.26	240
62 298 066	M4x9	5.14	023	M6x40	54.18	210	T15	12.26	113	M6x14	1.67	241
62 298 087	M5x10	5.84	232	M6x52	55.64	211	T20	13.11	114	M6x20	1.67	242
62 298 115	M5x10	5.84	232	M6x68	57.25	212	T20	13.11	114	M6x30	1.99	333
62 298 153	M5x10	5.84	232	M6x90	88.55	220	T20	13.11	114	M6x40	3.32	335

## Asynchronous machining (divided cut)

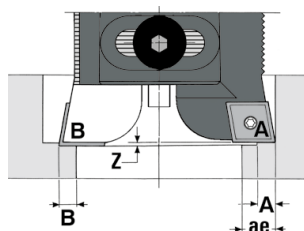

Asynchronous boring is possible using a tool holder (A) with offset 0.4mm. This tool holder is black finished and characterized by 3 dots, and must be in the outer position (with regard to the 2 tool holders)

## SpinTools – ER collet chuck

- ▲ for ER clamping to DIN 6499
- ▲ With internal coolant supply

### Scope of supply:

axial tool length adjustment and lock nut

STM

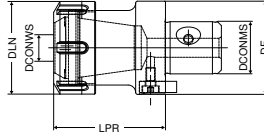

DCONWS	SZID	DCONMS	DF	DLN	LPR	for collet	WT	STM Modular W4	
mm		mm	mm	mm	mm		kg	Article no.	
1 - 20	STM 28	28	50	50	60	470E (ER32)	0.644	62 306 ...	
								£ 273.88	032

### Spare parts

for Article no.

62 306 032

Y8	W7	W7	Y8	W7
Y clamping key	Screw for drivers	Driver	Driver	Stop screw IK
Article no. 83 357 ...	Article no. 62 950 ...	Article no. 62 950 ...	Article no. 83 950 ...	Article no. 62 950 ...
£ 32.33 132	£ 1.67 166	£ 40.84 039	£ 14.10 121	£ 11.09 406

**i** Suitable collets can be found in → Chapter 16, Adapters

## SpinTools – Shell mill adapter

- ▲ for use on mills with parallel or transverse slot to ISO 3937
- ▲ With internal coolant supply

### Scope of supply:

drive dogs, drive key and clamping bolt

STM

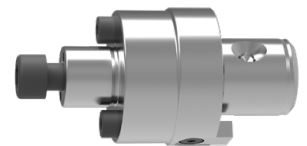
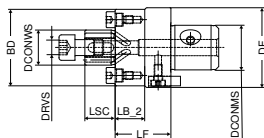

DCONWS	SZID	DCONMS	BD	DF	LSC	LB_2	LF	DRVS	WT	STM Modular W4	
mm		mm	mm	mm	mm	mm	mm	mm	kg	Article no.	
16	STM 22	22	38	40	17	17.1	30	6	0.363	62 307 ...	
22	STM 28	28	48	50	19	19.1	35	8	0.685	£ 215.08	016
										£ 220.44	022

### Spare parts

for Article no.

62 307 016

62 307 022

Y8	W7	W7	W7	Y8
Parallel key	Screw for drivers	Drive dogs	Driver	clamping screw
Article no. 83 950 ...	Article no. 62 950 ...	Article no. 62 950 ...	Article no. 62 950 ...	Article no. 83 950 ...
£ 3.29 284	£ 1.38 165	£ 22.29 442	£ 34.09 038	£ 5.65 113
£ 3.29 285	£ 1.67 166	£ 22.29 443	£ 40.84 039	£ 6.38 124



# SpinTools – Base adapters DIN 69871

STM

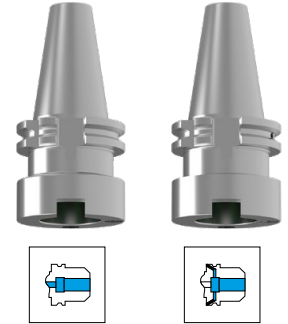
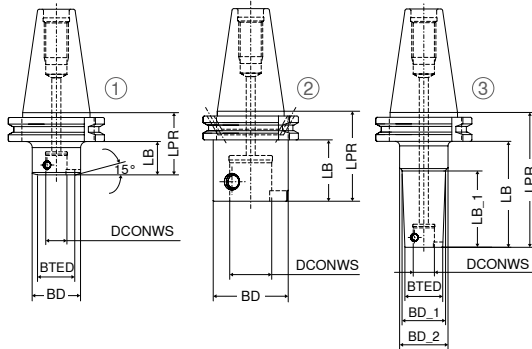

	Adapter	Fig.	SZID	DCONWS	BTED	BD	BD_1	BD_2	LPR	LB	LB_1	WT	AD SK W4		AD/B SK W4	
													Article no. 62 107 ...	Article no. 62 108 ...	Article no. 62 950 ...	Article no. 62 950 ...
				mm	mm	mm	mm	mm	mm	mm	mm	kg	£		£	
short	SK 30	2	STM 28	28		50			55	35.9		0.62	231.12	328		
	SK 40	1	STM 11	11	20	32			40	20.9		0.91	231.12	111	1)	
	SK 40	1	STM 14	14	25	32			40	20.9		0.93	231.12	114	1)	
	SK 40	2	STM 18	18		32			40	20.9		0.89	231.12	118		
	SK 40	2	STM 22	22		40			50	30.9		1.02	231.12	122		
	SK 40	2	STM 28	28		50			50	30.9		1.11	231.12	128	239.14	128
	SK 40	2	STM 36	36		63			60	40.9		1.27	213.76	136	239.14	136
	SK 50	2	STM 28	28		50			50	30.9		2.92	273.88	428	299.26	428
SK 50	2	STM 36	36		63			63	43.9		3.27	273.88	436	299.26	436	
long	SK 40	3	STM 11	11	20		23	32	80	60.9	40.9	1.04	256.50	211	1)	
	SK 40	3	STM 14	14	25		28	32	80	60.9	40.9	1.07	256.50	214	1)	
	SK 40	2	STM 18	18		32			80	60.9		1.13	256.50	218		
	SK 40	2	STM 22	22		40			100	80.9		1.47	256.50	222		
	SK 40	2	STM 28	28		50			100	80.9		1.84	256.50	228		
	SK 40	2	STM 36	36		63			120	100.9		2.68	256.50	236	281.89	236
	SK 50	2	STM 36	36		63			120	100.9		4.60	308.60	536	333.99	536

1) Note! BD/BD\_1 is larger than BTED, which may lead to a limited bore depth!



O-Ring



Clamping screw ST

Spare parts  
DCONWS

			Article no. 62 950 ...	Article no. 62 950 ...		Article no. 62 950 ...	Article no. 62 950 ...
			£	£		£	£
11		9x1,5	2.29	254	M4x0,5x6	9.68	026
14		12x1,5	2.29	255	M5x0,5x7,5	10.18	027
18		16x1,5	2.29	256	M6x0,75x9,5	10.42	028
22		19x2	2.29	257	M8x0,75x12	11.55	029
28		25x2	2.29	258	M10x1x14,2	13.55	030
36		33x2	2.29	259	M12x1x18	17.38	031

**i** Suitable pull studs can be found in → Chapter 16, Adapters

# SpinTools – Base adapters JIS B 6339 (MAS-BT)

▲ form B available upon request

STM

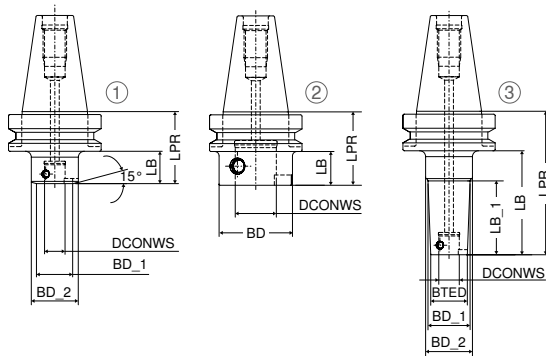

AD  
MAS-BT  
W4

5

	Adapter	Fig.	SZID	DCONWS	BTED	BD	BD_1	BD_2	LPR	LB	LB_1	WT	Article no.	
													mm	mm
short	BT 30	2	STM 28	28		50			55			0.64	231.12	328
	BT 40	1	STM 11	11	20	32			50	23		1.09	231.12	111 <sup>1)</sup>
	BT 40	1	STM 14	14	25	32			50	23		1.08	231.12	114 <sup>1)</sup>
	BT 40	2	STM 18	18		32			50	23		1.06	231.12	118
	BT 40	2	STM 22	22		40			50	23		1.10	231.12	122
	BT 40	2	STM 28	28		50			50	23		1.14	231.12	128
	BT 40	2	STM 36	36		63			60	33		1.38	213.76	136
	BT 50	2	STM 28	28		50			63	25		3.75	273.88	428
BT 50	2	STM 36	36		63			63	25		3.78	273.88	436	
long	BT 40	3	STM 11	11	20		23	32	90	63	43	1.20	256.50	211 <sup>1)</sup>
	BT 40	3	STM 14	14	25		28	32	90	63	43	1.24	256.50	214 <sup>1)</sup>
	BT 40	2	STM 18	18		32			90	63		1.30	256.50	218
	BT 40	2	STM 22	22		40			100	73		1.57	256.50	222
	BT 40	2	STM 28	28		50			100	73		1.87	256.50	228
	BT 40	2	STM 36	36		63			120	93		2.78	256.50	236
	BT 50	2	STM 36	36		63			120	82		5.18	308.60	536

1) Note! BD/BD\_1 is larger than BTED, which may lead to a limited bore depth!



O-Ring



Clamping screw  
ST

Spare parts  
DCONWS

SZID	DCONWS	Article no. 62 950 ...		Article no. 62 950 ...	
		£	254	£	256
11	9x1,5	2.29	254	M4x0,5x6	9.68 026
14	12x1,5	2.29	255	M5x0,5x7,5	10.18 027
18	16x1,5	2.29	256	M6x0,75x9,5	10.42 028
22	19x2	2.29	257	M8x0,75x12	11.55 029
28	25x2	2.29	258	M10x1x14,2	13.55 030
36	33x2	2.29	259	M12x1x18	17.38 031

1 Suitable pull studs can be found in → Chapter 16, Adapters

# SpinTools – Base adapters HSK-A ISO 12164-1 (DIN 69893-1)

STM

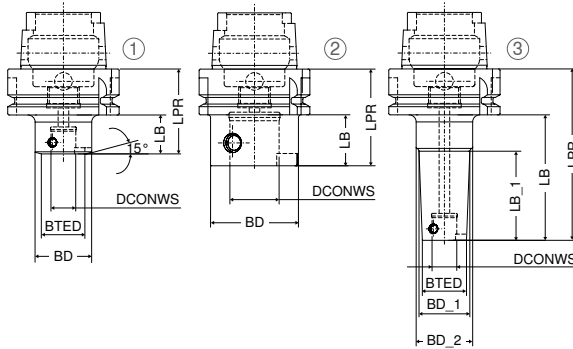

AD  
HSK-A  
W4

	Adapter	Fig.	SZID	DCONWS	BTED	BD	BD_1	BD_2	LPR	LB	LB_1	WT	Article no.	
													62 122 ...	£
short	HSK-A 63	1	STM 11	11	20	32			50	24		0.77	273.88	111 <sup>1)</sup>
	HSK-A 63	1	STM 14	14	25	32			50	24		0.76	273.88	114 <sup>1)</sup>
	HSK-A 63	2	STM 18	18		32			50	24		0.74	273.88	118
	HSK-A 63	2	STM 22	22		40			50	24		0.79	273.88	122
	HSK-A 63	2	STM 28	28		50			55	24		0.91	273.88	128
	HSK-A 63	2	STM 36	36		63			65	34		1.10	248.49	136
	HSK-A 100	2	STM 28	28		50			63	34		2.32	316.62	428
	HSK-A 100	2	STM 36	36		63			70	34		2.61	316.62	436
long	HSK-A 63	3	STM 11	11	20		23	32	90	64	44	0.87	299.26	211 <sup>1)</sup>
	HSK-A 63	3	STM 14	14	25		28	32	90	64	44	0.93	299.26	214 <sup>1)</sup>
	HSK-A 63	2	STM 18	18		32			90	64		0.98	299.26	218
	HSK-A 63	2	STM 22	22		40			100	74		1.26	299.26	222
	HSK-A 63	2	STM 28	28		50			100	74		1.58	299.26	228
	HSK-A 63	2	STM 36	36		63			120	94		2.41	316.62	236
	HSK-A 100	2	STM 36	36		63			120	91		3.77	342.01	536

1) Note! BD/BD\_1 is larger than BTED, which may lead to a limited bore depth!

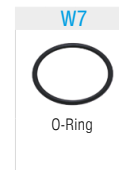

O-Ring

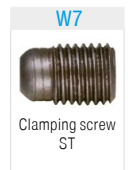

Clamping screw  
ST

Spare parts  
DCONWS

	Article no. 62 950 ...		Article no. 62 950 ...	
	£		£	
11	2.29	254	9.68	026
14	2.29	255	10.18	027
18	2.29	256	10.42	028
22	2.29	257	11.55	029
28	2.29	258	13.55	030
36	2.29	259	17.38	031

# SpinTools – Adapters to DIN 1835-B

▲ with thro' coolant

STM

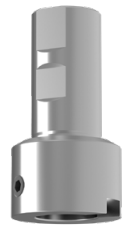
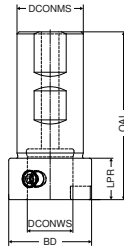

DIN 1835-B  
W4

DCONMS	BD	SZID	DCONWS	LPR	OAL	WT	Article no.	£	
mm	mm		mm	mm	mm	kg	62 104 ...		
25	25	STM 14	14	15	72	0.24	169.66		014
32	32	STM 18	18	15	76	0.42	175.01		018
32	50	STM 28	28	35	96	0.72	212.43		028
32	63	STM 36	36	45	106	1.05	233.79		036

# SpinTools – Base adapter DIN 2080

STM

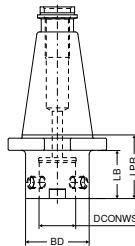

short  
SK  
W4

Adapter	SZID	DCONWS	BD	LPR	LB	WT	Article no.	£	
		mm	mm	mm	mm	kg	62 109 ...		
SK 40	STM 36	36	63	60	48.4	1.52	275.21		136
SK 50	STM 36	36	63	63	47.8	3.33	315.29		436

Spare parts  
DCONWS

DCONWS	Article no.	£	Article no.	£		
	62 950 ...		62 950 ...			
14	12x1,5	2.29	255	M5x0,5x7,5	10.18	027
18	16x1,5	2.29	256	M6x0,75x9,5	10.42	028
28	25x2	2.29	258	M10x1x14,2	13.55	030
36	33x2	2.29	259	M12x1x18	17.38	031

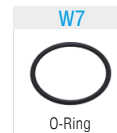

# SpinTools – Reductions

▲ With internal coolant supply



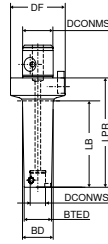

**STM**

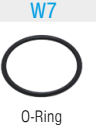

STM Modular  
W4

Adapter	LPR	SZID	DCONMS	DCONWS	DF	BTED	BD	LB	WT	Article no. 62 357 ...	£
	mm		mm	mm	mm	mm	mm	mm	kg		
STM 11	30	STM 14	14	11	25	20	23	15	0.04	111	125.84
STM 11	30	STM 18	18	11	32	20	23	17	0.14	211	125.84
STM 14	30	STM 18	18	14	32	25	28	17	0.16	214	125.84
STM 11	30	STM 22	22	11	40	20	23	15	0.21	311	131.14
STM 14	30	STM 22	22	14	40	25	28	15	0.22	314	131.14
STM 18	30	STM 22	22	18	40	32	37	15	0.25	318	131.14
STM 11	40	STM 28	28	11	50	20	23	20	0.44	411	136.45
STM 14	40	STM 28	28	14	50	25	28	20	0.49	414	136.45
STM 18	40	STM 28	28	18	50	32	37	20	0.45	418	136.45
STM 22	40	STM 28	28	22	50	40	46	20	0.55	422	136.45
STM 11	40	STM 36	36	11	63	20	22	16	0.82	511	144.40
STM 11	70	STM 36	36	11	63	20	23	42	0.90	811	156.30
STM 11	95	STM 36	36	11	63	20	23	71	0.98	611	169.56
STM 11	115	STM 36	36	11	63	20	23	87	1.02	911	186.77
STM 11	135	STM 36	36	11	63	20	23	111	1.08	711	204.01
STM 14	40	STM 36	36	14	63	25	27	16	0.84	514	144.40
STM 14	80	STM 36	36	14	63	25	28	52	1.00	814	165.58
STM 14	120	STM 36	36	14	63	25	28	96	1.16	614	186.77
STM 14	145	STM 36	36	14	63	25	28	117	1.27	914	204.01
STM 14	170	STM 36	36	14	63	25	28	146	1.38	714	221.21
STM 18	40	STM 36	36	18	63	32	37	16	0.85	518	144.40
STM 18	100	STM 36	36	18	63	32	38	74	1.24	818	176.18
STM 18	150	STM 36	36	18	63	32	38	126	1.66	918	206.64
STM 18	207	STM 36	36	18	63	32	38	183	2.07	618	254.32
STM 22	40	STM 36	36	22	63	40	46	16	0.89	522	144.40
STM 22	120	STM 36	36	22	63	40	48	95	1.76	822	190.75
STM 22	183	STM 36	36	22	63	40	48	159	2.52	622	237.12
STM 22	263	STM 36	36	22	63	40	48	239	3.44	722	339.12
STM 28	40	STM 36	36	28	63	50	58	21	1.03	528	144.40
STM 28	140	STM 36	36	28	63	50	60	117	2.70	828	200.02
STM 28	233	STM 36	36	28	63	50	60	209	4.41	628	321.89
STM 28	333	STM 36	36	28	63	50	60	309	6.25	728	441.10

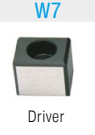
## Reductions – Spare Parts

		 W7 O-Ring		 W7 Screw for drivers		 W7 Driver		 W7 Clamping screw ST				
Spare parts		Article no. 62 950 ...		Article no. 62 950 ...		Article no. 62 950 ...		Article no. 62 950 ...				
for Article no.		£		£		£		£				
62 357 111	9x1,5	2.29	254	M2,5x6	1.12	163	6x10,3x4	28.78	036	M4x0,5x6	9.68	026
62 357 211	9x1,5	2.29	254	M3x8	1.38	164	8x15x5	30.22	037	M4x0,5x6	9.68	026
62 357 214	12x1,5	2.29	255	M3x8	1.38	164	8x15x5	30.22	037	M5x0,5x7,5	10.18	027
62 357 311	9x1,5	2.29	254	M4x10	1.38	165	10x18,1x6	34.09	038	M4x0,5x6	9.68	026
62 357 314	12x1,5	2.29	255	M4x10	1.38	165	10x18,1x6	34.09	038	M5x0,5x7,5	10.18	027
62 357 318	16x1,5	2.29	256	M4x10	1.38	165	10x18,1x6	34.09	038	M6x0,75x9,5	10.42	028
62 357 411	9x1,5	2.29	254	M5x10	1.67	166	12x20x6	40.84	039	M4x0,5x6	9.68	026
62 357 414	12x1,5	2.29	255	M5x10	1.67	166	12x20x6	40.84	039	M5x0,5x7,5	10.18	027
62 357 418	16x1,5	2.29	256	M5x10	1.67	166	12x20x6	40.84	039	M6x0,75x9,5	10.42	028
62 357 422	19x2	2.29	257	M5x10	1.67	166	12x20x6	40.84	039	M8x0,75x12	11.55	029
62 357 511	9x1,5	2.29	254	M6x12	1.67	167	16x26,5x8	51.87	040	M4x0,5x6	9.68	026
62 357 811	9x1,5	2.29	254	M6x12	1.67	167	16x26,5x8	51.87	040	M4x0,5x6	9.68	026
62 357 611	9x1,5	2.29	254	M6x12	1.67	167	16x26,5x8	51.87	040	M4x0,5x6	9.68	026
62 357 911	9x1,5	2.29	254	M6x12	1.67	167	16x26,5x8	51.87	040	M4x0,5x6	9.68	026
62 357 711	9x1,5	2.29	254	M6x12	1.67	167	16x26,5x8	51.87	040	M4x0,5x6	9.68	026
62 357 514	12x1,5	2.29	255	M6x12	1.67	167	16x26,5x8	51.87	040	M5x0,5x7,5	10.18	027
62 357 814	12x1,5	2.29	255	M6x12	1.67	167	16x26,5x8	51.87	040	M5x0,5x7,5	10.18	027
62 357 614	12x1,5	2.29	255	M6x12	1.67	167	16x26,5x8	51.87	040	M5x0,5x7,5	10.18	027
62 357 914	12x1,5	2.29	255	M6x12	1.67	167	16x26,5x8	51.87	040	M5x0,5x7,5	10.18	027
62 357 714	12x1,5	2.29	255	M6x12	1.67	167	16x26,5x8	51.87	040	M5x0,5x7,5	10.18	027
62 357 518	16x1,5	2.29	256	M6x12	1.67	167	16x26,5x8	51.87	040	M6x0,75x9,5	10.42	028
62 357 818	16x1,5	2.29	256	M6x12	1.67	167	16x26,5x8	51.87	040	M6x0,75x9,5	10.42	028
62 357 918	16x1,5	2.29	256	M6x12	1.67	167	16x26,5x8	51.87	040	M6x0,75x9,5	10.42	028
62 357 618	16x1,5	2.29	256	M6x12	1.67	167	16x26,5x8	51.87	040	M6x0,75x9,5	10.42	028
62 357 522	19x2	2.29	257	M6x12	1.67	167	16x26,5x8	51.87	040	M8x0,75x12	11.55	029
62 357 822	19x2	2.29	257	M6x12	1.67	167	16x26,5x8	51.87	040	M8x0,75x12	11.55	029
62 357 622	19x2	2.29	257	M6x12	1.67	167	16x26,5x8	51.87	040	M8x0,75x12	11.55	029
62 357 722	19x2	2.29	257	M6x12	1.67	167	16x26,5x8	51.87	040	M8x0,75x12	11.55	029
62 357 528	25x2	2.29	258	M6x12	1.67	167	16x26,5x8	51.87	040	M10x1x14,2	13.55	030
62 357 828	25x2	2.29	258	M6x12	1.67	167	16x26,5x8	51.87	040	M10x1x14,2	13.55	030
62 357 628	25x2	2.29	258	M6x12	1.67	167	16x26,5x8	51.87	040	M10x1x14,2	13.55	030
62 357 728	25x2	2.29	258	M6x12	1.67	167	16x26,5x8	51.87	040	M10x1x14,2	13.55	030

# SpinTools – Extensions

▲ With internal coolant supply

**STM**

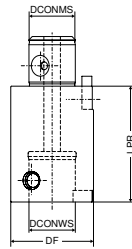

Adapter	LPR	SZID	DCONWS	DF	DCONMS	WT	STM Modular W4	
							Article no. 62 351 ...	£
STM 11	25	STM 11	11	20	11	0.06	120.23	111
STM 11	35	STM 11	11	20	11	0.09	120.23	211
STM 14	30	STM 14	14	25	14	0.11	120.23	114
STM 14	45	STM 14	14	25	14	0.17	120.23	214
STM 18	40	STM 18	18	32	18	0.23	128.25	118
STM 18	60	STM 18	18	32	18	0.35	127.16	218
STM 22	50	STM 22	22	40	22	0.45	137.62	122
STM 22	80	STM 22	22	40	22	0.73	136.45	222
STM 28	50	STM 28	28	50	28	0.71	137.62	128
STM 28	75	STM 28	28	50	28	1.07	144.40	228
STM 28	100	STM 28	28	50	28	1.44	152.33	328
STM 36	60	STM 36	36	63	36	1.33	145.63	136
STM 36	90	STM 36	36	63	36	2.02	161.61	236
STM 36	120	STM 36	36	63	36	2.72	178.82	336

Spare parts DCONWS	W7 O-Ring		W7 Screw for drivers		W7 Driver		W7 Clamping screw ST	
	Article no. 62 950 ...	£	Article no. 62 950 ...	£	Article no. 62 950 ...	£	Article no. 62 950 ...	£
11	9x1,5	2.29 254	M2x2,5	1.12 162	5x8,5x3	26.93 035	M4x0,5x6	9.68 026
14	12x1,5	2.29 255	M2,5x6	1.12 163	6x10,3x4	28.78 036	M5x0,5x7,5	10.18 027
18	16x1,5	2.29 256	M3x8	1.38 164	8x15x5	30.22 037	M6x0,75x9,5	10.42 028
22	19x2	2.29 257	M4x10	1.38 165	10x18,1x6	34.09 038	M8x0,75x12	11.55 029
28	25x2	2.29 258	M5x10	1.67 166	12x20x6	40.84 039	M10x1x14,2	13.55 030
36	33x2	2.29 259	M6x12	1.67 167	16x26,5x8	51.87 040	M12x1x18	17.38 031

## WCMT / WCGT

Designation	L	S	D1	IC
	mm	mm	mm	mm
WCGT 0201..	2.71	1.59	2.1	3.97
WCMT 0201..	4.34	1.59	2.1	3.97

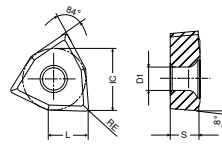

WCMT

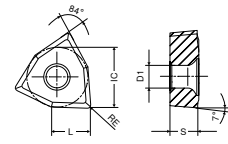

WCGT

## WCMT / WCGT

ISO	RE	CWC06		CWN10		CWP25	
		Article no.	£	Article no.	£	Article no.	£
020102	0.2	70 294 ...	14.15	70 295 ...	89.65	70 295 ...	40.47
020104	0.4				89.65		500
Steel		●		●		●	
Stainless steel		○		●		●	
Cast iron		●		●		○	
Non ferrous metals		●		●		●	
Heat resistant alloys		○		●		●	
hardened materials						●	

→ v<sub>c</sub> Page 52

**i** Additional inserts can be found in → Chapter 9, Turning Tools



### CCGT

Designation	L	S	D1	IC
	mm	mm	mm	mm
CCGT 06..	6.4	2.38	2.8	6.35
CCGT 09..	9.7	3.97	4.4	9.52

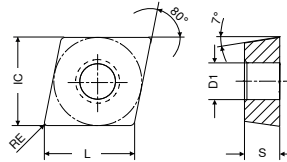

### CCGT

ISO	RE	CWN10		CWC06		CWC10	
		Article no.	Price (£)	Article no.	Price (£)	Article no.	Price (£)
	mm	70 296 ...		70 296 ...		70 300 ...	
060202L	0.2	63.33 300		40.88 850		15.09 903	
060204L	0.4	63.33 302		40.88 852		15.09 905	
09T302L	0.2	68.37 304		44.21 854		18.81 911	
09T304L	0.4	68.37 306		44.21 856		18.81 913	
Steel		●		●		●	
Stainless steel		●		○		●	
Cast iron		●		●		●	
Non ferrous metals		●		●		●	
Heat resistant alloys		●		○		●	
hardened materials		●					

→ v<sub>c</sub> Page 52

**i** Additional inserts can be found in → **Chapter 9, Turning Tools**

# Material examples referring to the cutting data tables

	Index	Material	Strength N/mm <sup>2</sup> / HB / HRC	Material number	Material designation	Material number	Material designation	Material number	Material designation
P	1.1	General construction steel	< 800 N/mm <sup>2</sup>	1.0402	EN3B				
	1.2	Free cutting steel	< 800 N/mm <sup>2</sup>	1.0711	EN1A				
	1.3	Hardened steel, non alloyed	< 800 N/mm <sup>2</sup>	1.0401	EN32C				
	1.4	Alloyed hardened steel	< 1000 N/mm <sup>2</sup>	1.7325	25 CD4				
	1.5	Tempering steel, unalloyed	< 850 N/mm <sup>2</sup>	1.5752	EN36	1.0535	EN9		
	1.6	Tempering steel, unalloyed	< 1000 N/mm <sup>2</sup>	1.6582	EN24				
	1.7	Tempering steel, alloyed	< 800 N/mm <sup>2</sup>	1.7225	EN19				
	1.8	Tempering steel, alloyed	< 1300 N/mm <sup>2</sup>	1.8515	EN40B				
	1.9	Steel castings	< 850 N/mm <sup>2</sup>	0.9650	G-X 260 Cr 27	1.6750	GS-20 NiCrMo 3.7	1.6582	GS-34 CrNiMo 6
	1.10	Nitriding steel	< 1000 N/mm <sup>2</sup>	1.8509	EN41B				
	1.11	Nitriding steel	< 1200 N/mm <sup>2</sup>	1.1186	EN8	1.1160	EN14A		
	1.12	Roller bearing steel	< 1200 N/mm <sup>2</sup>	1.3505	534A99				
	1.13	Spring steel	< 1200 N/mm <sup>2</sup>		EN45		EN47		EN43
	1.14	High-speed steel	< 1300 N/mm <sup>2</sup>	1.3343	M2	1.3249	M34		
	1.15	Cold working tool steel	< 1300 N/mm <sup>2</sup>	1.2379	D2	1.2311	P20		
	1.16	Hot working tool steel	< 1300 N/mm <sup>2</sup>	1.2344	H13				
M	2.1	Cast steel and sulphured stainless steel	< 850 N/mm <sup>2</sup>	1.4581	318				
	2.2	Stainless steel, ferritic	< 750 N/mm <sup>2</sup>	1.4000	403				
	2.3	Stainless steel, martensitic	< 900 N/mm <sup>2</sup>	1.4057	EN57				
	2.4	Stainless steel, ferritic / martensitic	< 1100 N/mm <sup>2</sup>	1.4028	EN56B				
	2.5	Stainless steel, austenitic / ferritic	< 850 N/mm <sup>2</sup>	1.4542	17-4PH				
	2.6	Stainless steel, austenitic	< 750 N/mm <sup>2</sup>	1.4305	303	1.4401	316	1.4301	304
	2.7	Heat resistant steel	< 1100 N/mm <sup>2</sup>	1.4876	Incoloy 800				
K	3.1	Grey cast iron with lamellar graphite	100-350 N/mm <sup>2</sup>	0.6015	Grade 150	0.6020	Grade 220	0.6025	Grade 260
	3.2	Grey cast iron with lamellar graphite	300-500 N/mm <sup>2</sup>	0.6030	Grade 300	0.6035	Grade 350	0.6040	Grade 400
	3.3	Gray cast iron with spheroidal graphite	300-500 N/mm <sup>2</sup>	0.7040	SG 400-12	0.7043	SG 370-17	0.7050	SG 500-7
	3.4	Gray cast iron with spheroidal graphite	500-900 N/mm <sup>2</sup>	0.7060	SG 600-3	0.7070	SG 700-2	0.7080	SG 800-2
	3.5	White malleable cast iron	270-450 N/mm <sup>2</sup>	0.8035	GTW-35	0.8045	GTW-45		
	3.6	White malleable cast iron	500-650 N/mm <sup>2</sup>	0.8055	GTW-55	0.8065	GTW-65		
	3.7	Black malleable cast iron	300-450 N/mm <sup>2</sup>	0.8135	GTS-35	0.8145	GTS-45		
	3.8	Black malleable cast iron	500-800 N/mm <sup>2</sup>	0.8155	GTS-55	0.8170	GTS-70		
N	4.1	Aluminium (non alloyed, low alloyed)	< 350 N/mm <sup>2</sup>	3.0255	1050 A	3.0275	1070 A	3.0285	1080 A (A8)
	4.2	Aluminium alloys < 0.5 % Si	< 500 N/mm <sup>2</sup>	3.1325	2017 A (AU4G)	3.4335	7005 (AZ5G)	3.4365	7075 (AZ5GU)
	4.3	Aluminium alloy 0.5-10 % Si	< 400 N/mm <sup>2</sup>	3.2315	A-G S1	3.2373	A-S9 G	3.2151	A-S6 U4
	4.4	Aluminium alloys 10-15 % Si	< 400 N/mm <sup>2</sup>	3.2581	A-S12	3.2583	A-S12 U		
	4.5	Aluminum alloys > 15 % Si	< 400 N/mm <sup>2</sup>		A-S18		A-S17 U4		
	4.6	Copper (non alloyed, low alloyed)	< 350 N/mm <sup>2</sup>	2.0040	Cu-c1	2.0060	Cu-a1	2.0090	Cu-b1
	4.7	Copper wrought alloys	< 700 N/mm <sup>2</sup>	2.1247	Cub2 (Beryllium Copper)	2.0855	CuN2S (Nickel Copper)	2.1310	CU-Fe2P
	4.8	Special copper alloys	< 200 HB	2.0916	Cu-A5	2.1525	Cu-S3 M		Ampco 8 (Cu-A6Fe2)
	4.9	Special copper alloys	< 300 HB	2.0978	Cu-Ai11 Fe5 Ni5)		Ampco 18 (Cu-A10 Fe3)		
	4.10	Special copper alloys	> 300 HB	2.1247	Cu Be2		Ampco M4		
	4.11	Short-chipping brass, bronze, red bronze	< 600 N/mm <sup>2</sup>	2.0331	Cu Zn36 Pb1,5	2.0380	Cu Zn39 Pb2 (Ms 56)	2.0410	Cu Zn44 Pb2
	4.12	Long-chipping brass	< 600 N/mm <sup>2</sup>	2.0335	Cu Zn 36 (Ms63)	2.1293	Cu Cr1 Zr		
	4.13	Thermoplastics			PE		PS		Plexiglas
	4.14	Duroplastics			PF		Bakelite		Pertinax
	4.15	Fibre-reinforced plastics			Carbon Fibre		Fibreglass		Aramid Fibre (Kevlar)
	4.16	Magnesium and magnesium alloys	< 850 N/mm <sup>2</sup>	3.5812	Mg A7 Z1	3.5662	Mg A9	3.5105	Mg Tr3 Z2 Zn 1
	4.17	Graphite			R8500X		R8650		Technograph 15
	4.18	Tungsten and tungsten alloys			W-Ni Fe (Densimet)		W- Ni Cu (Inermet)		Denal
	4.19	Molybdenum and molybdenum alloys			TZM		MHO		Mo W
S	5.1	Pure nickel		2.4066	Ni99 (Nickel 200)	2.4068	Lc Ni99 (Nickel 201)		
	5.2	Nickel alloys		1.3912	Fe-Ni36 (Invar)	1.3917	Fe-Ni42 (N42)	1.3922	Fe-Ni48 (N48)
	5.3	Nickel alloys	< 850 N/mm <sup>2</sup>	2.4375	Ni Cu30 Al (Monel K500)	2.4360	Ni Cu30Fe (Monel 400)	2.4668	
	5.4	Nickel molybdenum alloys		2.4600	Ni Mo30Cr2 (Hastelloy B4)	2.4617	Ni Mo28 (Hastelloy B2)	2.4819	Ni Mo16Cr16 Hastell. C276
	5.5	Nickel-chromium alloys	< 1300 N/mm <sup>2</sup>	2.4951	Ni Cr20TiAl (Nimonic 80A)	2.4858	Ni Cr21Mo (Inconel 825)	2.4856	Ni Cr22Mo9Nb Inconel 625
	5.6	Cobalt Chrome Alloys	< 1300 N/mm <sup>2</sup>	2.4964	Co Cr20 W15 Ni10		Co Cr20 Ni16 Mo7		Co Cr28 Mo 6
	5.7	Heat resistant alloys	< 1300 N/mm <sup>2</sup>	1.4718	Z45 C S 9-3	1.4747	Z80 CSN 20-02	1.4845	Z12 CN 25-20
	5.8	Nickel-cobalt-chromium alloys	< 1400 N/mm <sup>2</sup>	2.4851	Ni Cr23Fe (Inconel 601)	2.4668	Ni Cr19NbMo (Inconel 718)	2.4602	Ni Cr21Mo14 Hastelloy C22
	5.9	Pure titanium	< 900 N/mm <sup>2</sup>	3.7025	T35 (Titanium Grade 1)	3.7034	T40 (Titanium Grade 2)	3.7064	T60 (Titanium Grade 4)
	5.10	Titanium alloys	< 700 N/mm <sup>2</sup>		T-A6-Nb7 (367)		T-A5-Sn2-Mo4-Cr4 (Ti17)		T-A3-V2,5 (Gr18)
	5.11	Titanium alloys	< 1200 N/mm <sup>2</sup>	3.7165	T-A6-V4 (Ta6V)		T-A4-3V-Mo2-Fe2 (SP700)		T-A5-Sn1-Zr1-V1-Mo (Gr32)
H	6.1		< 45 HRC						
	6.2		46-55 HRC						
	6.3	Tempered steel	56-60 HRC						
	6.4		61-65 HRC						
	6.5		65-70 HRC						

# Cutting data standard values for precision adjustment heads

Fine machining with depth of cut  $a_p = 0.1 - 0.2$  mm

Index	Insert								Tool diameter Ø 6-125	● 1st choice ○ suitable		
	BK8440	BK8425	BK2710	K10	BK60	BK6110	BK7615	CBN40		Emulsion	Compressed air	MMS
	$V_c$ m/min	$V_c$ m/min	$V_c$ m/min	$V_c$ m/min	$V_c$ m/min	$V_c$ m/min	$V_c$ m/min	$V_c$ m/min	f (mm/U)			
1.1	150-220	150-240	150-240		150-240	150-240			0,04-0,12	●	○	
1.2	150-220	150-240	150-240		150-240	150-240			0,04-0,12	●	○	
1.3	150-220	150-240	150-240		150-240	150-240			0,04-0,10	●	○	
1.4	150-220	150-240	150-240		150-240	150-240			0,04-0,10	●	○	
1.5	150-220	150-240	150-240		150-240	150-240			0,04-0,10	●	○	
1.6	150-220	150-240	150-240		150-240	150-240			0,04-0,10	●	○	
1.7	150-220	150-240	150-240		150-240	150-240			0,04-0,10	●	○	
1.8	150-220	150-240	150-240		150-240	150-240			0,04-0,10	○	●	
1.9	150-220	150-240	150-240		150-240	150-240			0,04-0,10	○	●	
1.10	150-220	150-240	150-240		150-240	150-240			0,04-0,10	○	●	
1.11	150-220	150-240	150-240		150-240	150-240			0,04-0,10	○	●	
1.12	150-220	150-240	150-240		150-240	150-240			0,04-0,10	○	●	
1.13	150-220	150-240	150-240		150-240	150-240			0,04-0,10	○	●	
1.14	60-120	60-120	60-120		60-120	60-120			0,02-0,08	○	●	
1.15	60-120	60-150	60-150		60-150	60-150			0,03-0,10	○	●	
1.16	100-150	100-150	100-150		100-150	100-150			0,03-0,10	○	●	
2.1	100-150	100-150	100-150						0,01-0,10	●		
2.2	100-150	100-150	100-150						0,01-0,10	●		
2.3	100-150	100-150	100-150						0,01-0,10	●		
2.4	100-120	100-120	100-120						0,01-0,10	●		
2.5	100-140	100-140	100-140						0,01-0,10	●		
2.6	100-140	100-140	100-140						0,01-0,10	●		
2.7	80-100	80-100	80-100						0,01-0,10	●		
3.1		120-180	120-180			120-180	120-180		0,03-0,15	○	●	
3.2		120-180	120-180			120-180	120-180		0,03-0,15	○	●	
3.3		120-180	120-180			120-180	120-180		0,03-0,15	○	●	
3.4		120-180	120-180			120-180	120-180		0,03-0,15	○	●	
3.5		120-180	120-180			120-180	120-180		0,03-0,15	○	●	
3.6		120-180	120-180			120-180	120-180		0,03-0,15	○	●	
3.7		120-180	120-180			120-180	120-180		0,03-0,15	○	●	
3.8		120-180	120-180			120-180	120-180		0,03-0,15	○	●	
4.1				0-500					0,02-0,12	●		
4.2				0-500					0,02-0,12	●		
4.3				0-500					0,02-0,12	●		
4.4				0-500					0,02-0,12	●		
4.5				0-500					0,02-0,12	●		
4.6				0-500					0,02-0,12	●		
4.7				0-500					0,02-0,12	●		
4.8												
4.9												
4.10												
4.11				0-500					0,02-0,12	●		
4.12				0-500					0,02-0,12	●		
4.13												
4.14												
4.15												
4.16												
4.17												
4.18												
4.19												
5.1												
5.2												
5.3												
5.4												
5.5				20-50					0,01-0,08	●		
5.6												
5.7				20-50					0,01-0,08	●		
5.8												
5.9				15-30					0,01-0,08	●		
5.10				15-30					0,01-0,08	●		
5.11				15-30					0,01-0,08	●		
6.1								80	0,04-0,08		●	
6.2								60	0,04-0,08		●	
6.3								60	0,04-0,08		●	
6.4											●	
6.5											●	

# Cutting data values for rough boring heads

Depth of cut  $a_p = 2.5 - 7 \text{ mm}$

Index	Insert					Tool Ø (mm)				● 1st choice ○ suitable		
	CTCP125 (HCX1125)	CTCP115 (HCX1115)	CTCP135 (HCR1135)	CTC2135 (CWN2135)	H10T (CWK15)	Ø 23,5-40,5	Ø 40,5-66,5	Ø 66,5-87,5	Ø 87,5-153	Emulsion	Compressed air	MMS
	$V_c$ m/min	$V_c$ m/min	$V_c$ m/min	$V_c$ m/min	$V_c$ m/min	f (mm/U)	f (mm/U)	f (mm/U)	f (mm/U)			
1.1	180-240	150-190	160-200	160-210		0,3-0,4	0,4-0,5	0,5-0,7	0,6-0,8	●	○	○
1.2	230-280	170-220	170-220	180-230		0,3-0,4	0,4-0,5	0,5-0,7	0,6-0,8	●	○	○
1.3	240-290	170-210	150-190	150-190		0,3-0,4	0,4-0,5	0,5-0,7	0,6-0,8	●	○	○
1.4	180-250	160-200	160-200	150-190		0,3-0,5	0,4-0,6	0,5-0,7	0,6-0,8	●	○	○
1.5	200-240	170-230	140-190	140-190		0,3-0,4	0,4-0,5	0,4-0,6	0,6-0,8	●	○	○
1.6	190-240	160-240	150-210	150-210		0,3-0,4	0,4-0,5	0,4-0,6	0,6-0,8	●	○	○
1.7	180-280	130-190	150-190	150-200		0,3-0,5	0,4-0,6	0,5-0,7	0,6-0,8	●	○	○
1.8	150-210	130-180	130-170	130-170		0,3-0,5	0,4-0,6	0,5-0,7	0,6-0,8	○	●	
1.9	140-200	150-210	150-180	160-190		0,3-0,5	0,4-0,6	0,5-0,7	0,6-0,8	○	●	
1.10	170-220	160-200	130-180	130-170		0,3-0,4	0,4-0,5	0,4-0,6	0,6-0,8	○	●	
1.11	160-220	150-200	120-160	130-170		0,3-0,4	0,4-0,5	0,4-0,6	0,6-0,8	○	●	
1.12	170-240	170-210	140-190	160-190		0,3-0,4	0,4-0,5	0,4-0,6	0,6-0,8	○	●	
1.13	160-230	130-190	120-170	120-180		0,3-0,4	0,4-0,5	0,4-0,6	0,6-0,8	○	●	
1.14	150-190	150-200	110-150	120-170		0,3-0,4	0,4-0,5	0,4-0,6	0,6-0,8	○	●	
1.15	150-210	130-200	100-140	100-150		0,3-0,4	0,4-0,5	0,4-0,6	0,6-0,8	○	●	
1.16	150-190	130-200	100-140	100-150		0,3-0,4	0,4-0,5	0,4-0,6	0,6-0,8	○	●	
2.1	200-280		140-200	140-220		0,3-0,4	0,4-0,5	0,4-0,6	0,6-0,8	●		
2.2	200-260		140-190	160-240		0,3-0,4	0,4-0,5	0,4-0,6	0,6-0,8	●		
2.3	190-260		110-190	130-200		0,3-0,4	0,4-0,5	0,4-0,6	0,6-0,8	●		
2.4	190-240		100-180	120-190		0,3-0,4	0,4-0,5	0,4-0,6	0,6-0,8	●		
2.5			80-150	100-160		0,3-0,4	0,4-0,5	0,4-0,6	0,6-0,8	●		
2.6			55-75	90-120		0,3-0,4	0,4-0,5	0,4-0,6	0,6-0,8	●		
2.7			55-75	90-120		0,3-0,4	0,4-0,5	0,4-0,6	0,6-0,8	●		
3.1	130-160	150-220			120-160	0,3-0,5	0,4-0,6	0,6-0,8	0,6-1,0	○	●	
3.2	120-170	130-220			90-140	0,3-0,5	0,4-0,6	0,6-0,8	0,6-1,0	○	●	
3.3	130-180	200-360			130-170	0,3-0,5	0,4-0,6	0,6-0,8	0,6-1,0	○	●	
3.4	100-180	180-220			90-130	0,3-0,5	0,4-0,6	0,6-0,8	0,6-1,0	○	●	
3.5	150-200	160-350			140-200	0,3-0,5	0,4-0,6	0,6-0,8	0,6-1,0	○	●	
3.6	130-160	160-260			120-160	0,3-0,5	0,4-0,6	0,6-0,8	0,6-1,0	○	●	
3.7	150-200	180-350			140-200	0,3-0,5	0,4-0,6	0,6-0,8	0,6-1,0	○	●	
3.8	130-180	180-350			120-160	0,3-0,5	0,4-0,6	0,6-0,8	0,6-1,0	○	●	
4.1					300-2500	0,3-0,5	0,4-0,7	0,5-0,7	0,6-0,8	●		○
4.2					200-2500	0,3-0,5	0,4-0,7	0,5-0,7	0,6-0,8	●		○
4.3					400-2000	0,3-0,5	0,4-0,7	0,5-0,7	0,6-0,8	●		○
4.4					400-1600	0,3-0,5	0,4-0,7	0,5-0,7	0,6-0,8	●		○
4.5					200-1000	0,3-0,5	0,4-0,7	0,5-0,7	0,6-0,8	●		○
4.6					150-300	0,3-0,5	0,4-0,7	0,5-0,7	0,6-0,8	●		○
4.7					250-600	0,3-0,5	0,4-0,7	0,5-0,7	0,6-0,8	●		○
4.8					150-400							
4.9					150-400							
4.10					150-400							
4.11					150-300	0,3-0,5	0,4-0,7	0,5-0,7	0,6-0,8	●		○
4.12					130-350	0,3-0,5	0,4-0,7	0,5-0,7	0,6-0,8	●		○
4.13					100-200							
4.14					80-160							
4.15					60-150							
4.16												
4.17												
4.18					60-140					●		
4.19												
5.1			20-40	20-40						●		
5.2		15-40	20-40	20-40						●		
5.3		15-40	8-25	15-35						●		
5.4		15-40	8-25	15-35						●		
5.5		15-30	4-15	8-25						●		
5.6		15-30	4-15	4-15						●		
5.7		15-30	4-15	4-15						●		
5.8		15-30	4-12	4-15						●		
5.9			80-130	80-130	60-120					●		
5.10			15-35	15-35	30-80					●		
5.11			15-35	15-35	30-80					●		
6.1						0,05-0,16	0,05-0,16	0,05-0,16	0,05-0,16		●	
6.2						0,05-0,16	0,05-0,16	0,05-0,16	0,05-0,16		●	
6.3						0,05-0,16	0,05-0,16	0,05-0,16	0,05-0,16		●	
6.4						0,05-0,16	0,05-0,16	0,05-0,16	0,05-0,16		●	
6.5												

# Cutting data values for fine and rough boring heads

Fine machining with depth of cut  $a_p = 0.1 - 0.4$  mm

Index	Insert			Boring tools with carbide cutting edge	Tool diameter		● 1st choice ○ suitable		
	CWN10 CWP25	CWC06	CWC10	K10	Ø 3-200	Ø 200-655	Emulsion	Compressed air	MMS
	$v_c$ m/min	$v_c$ m/min	$v_c$ m/min	$v_c$ m/min	f (mm/U)	f (mm/U)			
1.1	150-220	<b>200-300</b>	<b>100-250</b>	150-200	0,05-0,16	0,08-0,2	●	○	○
1.2	150-220	<b>200-300</b>	<b>100-250</b>	150-200	0,05-0,16	0,08-0,2	●	○	○
1.3	150-220	<b>200-300</b>	<b>100-250</b>	150-200	0,05-0,16	0,08-0,2	●	○	○
1.4	150-220	<b>200-300</b>	<b>100-250</b>	150-200	0,05-0,16	0,08-0,2	●	○	○
1.5	150-220	<b>200-300</b>	<b>80-200</b>	150-200	0,05-0,16	0,08-0,2	●	○	○
1.6	150-220	<b>200-300</b>	<b>80-200</b>	150-200	0,05-0,16	0,08-0,2	●	○	○
1.7	150-220	<b>200-300</b>	<b>80-200</b>	150-200	0,05-0,16	0,08-0,2	●	○	○
1.8	150-220	<b>200-300</b>	<b>80-200</b>	150-200	0,05-0,16	0,08-0,2	○	●	
1.9	150-220	<b>200-300</b>	<b>80-150</b>	150-200	0,05-0,16	0,08-0,2	○	●	
1.10	150-220	<b>200-300</b>	<b>100-250</b>	150-200	0,05-0,16	0,08-0,2	○	●	
1.11	150-220	<b>200-250</b>	<b>100-250</b>	80-120	0,05-0,16	0,08-0,2	○	●	
1.12	150-220	<b>200-250</b>	<b>80-200</b>	80-120	0,05-0,16	0,08-0,2	○	●	
1.13	120-150	<b>150-180</b>	<b>80-200</b>	50-80	0,05-0,16	0,08-0,2	○	●	
1.14	120-150	<b>150-180</b>	<b>80-200</b>	50-80	0,05-0,16	0,08-0,2	○	●	
1.15	120-150	<b>150-180</b>	<b>80-200</b>	50-80	0,05-0,16	0,08-0,2	○	●	
1.16	120-150	<b>150-180</b>	<b>80-200</b>	50-80	0,05-0,16	0,08-0,2	○	●	
2.1	100-140	100-140	<b>100-140</b>	80-120	0,05-0,16	0,08-0,2	●		
2.2	100-140	100-140	<b>100-140</b>	80-120	0,05-0,16	0,08-0,2	●		
2.3	100-140	100-140	<b>100-140</b>	80-120	0,05-0,16	0,08-0,2	●		
2.4	80-120	80-120	<b>100-120</b>	60-80	0,05-0,16	0,08-0,2	●		
2.5	100-140	100-140	<b>100-140</b>	80-120	0,05-0,16	0,08-0,2	●		
2.6	100-140	100-140	<b>100-140</b>	80-120	0,05-0,16	0,08-0,2	●		
2.7	80-100	80-100	<b>100-140</b>	40-60	0,05-0,16	0,08-0,2	●		
3.1	140-180	<b>140-180</b>	<b>200-250</b>	120-150	0,05-0,16	0,08-0,2	○	●	
3.2	140-180	<b>140-180</b>	<b>200-250</b>	120-150	0,05-0,16	0,08-0,2	○	●	
3.3	140-180	<b>140-180</b>	<b>100-150</b>	120-150	0,05-0,16	0,08-0,2	○	●	
3.4	120-160	<b>120-160</b>	<b>100-150</b>	100-130	0,05-0,16	0,08-0,2	○	●	
3.5	140-180	<b>140-180</b>	<b>200-250</b>	120-150	0,05-0,16	0,08-0,2	○	●	
3.6	120-160	<b>120-160</b>	<b>100-150</b>	100-130	0,05-0,16	0,08-0,2	○	●	
3.7	140-180	<b>140-180</b>	<b>200-250</b>	120-150	0,05-0,16	0,08-0,2	○	●	
3.8	120-160	<b>120-160</b>	<b>100-150</b>	100-130	0,05-0,16	0,08-0,2	○	●	
4.1	0-800	<b>0-800</b>		0-500	0,05-0,16	0,08-0,2	●		○
4.2	0-800	<b>0-800</b>		0-500	0,05-0,16	0,08-0,2	●		○
4.3	0-800	<b>0-800</b>		0-500	0,05-0,16	0,08-0,2	●		○
4.4	0-800	<b>0-800</b>		0-500	0,05-0,16	0,08-0,2	●		○
4.5	0-800	<b>0-800</b>		0-500	0,05-0,16	0,08-0,2	●		○
4.6	0-800	<b>0-800</b>		0-500	0,05-0,16	0,08-0,2	●		○
4.7	0-800	<b>0-800</b>		0-500	0,05-0,16	0,08-0,2	●		○
4.8						0,08-0,2			
4.9						0,08-0,2			
4.10						0,08-0,2			
4.11	0-800	<b>0-800</b>		0-500	0,05-0,16	0,08-0,2	●		○
4.12	0-800	<b>0-800</b>		0-500	0,05-0,16	0,08-0,2	●		○
4.13									
4.14									
4.15									
4.16									
4.17									
4.18									
4.19									
5.1	30-80*								
5.2	30-80*								
5.3	30-80*								
5.4	30-80*								
5.5	30-80*								
5.6	30-80*								
5.7	30-80*								
5.8	30-80*								
5.9	30-80*								
5.10	30-80*								
5.11	30-80*								
6.1	120-220*				0,05-0,16	0,05-0,16		●	
6.2	70-180*				0,05-0,16	0,05-0,16		●	
6.3	50-150*				0,05-0,16	0,05-0,16		●	
6.4	40-120*				0,05-0,16	0,05-0,16		●	
6.5									

**i** Correction factor (Kf  $v_c$ ) for the cutting speed ( $v_c$ ) depending on overhang:  
 Kf  $v_c = 1,0$  to 4xD  
 Kf  $v_c = 0,8$  to 5xD  
 Kf  $v_c = 0,6$  to 6xD

## Cutting data values for Micro boring heads

Index	Boring bars / inserts		● 1st choice ○ suitable		
	TiN		Emulsion	Compressed air	MMS
	v <sub>c</sub> m/min	f (mm/U)			
1.1	190	0,02	●		
1.2	210	0,02	●		
1.3	190	0,02	●		
1.4	170	0,02	●		
1.5	180	0,02	●		
1.6	180	0,02	●		
1.7	170	0,02	●		
1.8	170	0,02	●		
1.9	110	0,02	●		
1.10	120	0,02	●		
1.11	100	0,02	●		
1.12	160	0,02	●		
1.13	140	0,02	●		
1.14	60	0,02	●		
1.15	100	0,02	●		
1.16	110	0,02	●		
2.1	80	0,02	●		
2.2	85	0,02	●		
2.3	75	0,02	●		
2.4	70	0,02	●		
2.5	75	0,02	●		
2.6	75	0,02	●		
2.7	70	0,02	●		
3.1	200	0,02	●		
3.2	150	0,02	●		
3.3	120	0,02	●		
3.4	110	0,02	●		
3.5	180	0,02	●		
3.6	150	0,02	●		
3.7	180	0,02	●		
3.8	150	0,02	●		
4.1	300	0,02	●		
4.2	240	0,02	●		
4.3	240	0,02	●		
4.4	180	0,02	●		
4.5	180	0,02	●		
4.6	290	0,02	●		
4.7	290	0,02	●		
4.8	240	0,02	●		
4.9	230	0,02	●		
4.10	210	0,02	●		
4.11	290	0,02	●		
4.12	290	0,02	●		
4.13	300	0,02	●		
4.14	280	0,02	●		
4.15	250	0,02	●		
4.16	220	0,02	●		
4.17	300	0,02	●		
4.18	60	0,02	●		
4.19	60	0,02	●		
5.1	60	0,02	●		
5.2	40	0,02	●		
5.3	30	0,02	●		
5.4	20	0,02	●		
5.5	20	0,02	●		
5.6	20	0,02	●		
5.7	20	0,02	●		
5.8	20	0,02	●		
5.9	30	0,02	●		
5.10	40	0,02	●		
5.11	25	0,02	●		
6.1	120	0,02	●		
6.2	110	0,02	●		
6.3	95	0,02	●		
6.4	70	0,02	●		
6.5	50	0,02	●		

## Maximum Speeds and Scale Accuracy

### Maximum speeds for fine boring heads Ø 3–88.1 mm

Boring range	Offset	
	X = ≤ 0,5 mm n <sub>max</sub> in 1/min	X = > 0,5 mm n <sub>max</sub> in 1/min
Ø 3–20 mm	16000	6000
Ø 20–48 mm	12000	4000
Ø 48–88 mm	8000	2000



### Maximum speeds for rough boring heads Ø 23.5–153 mm

Boring range	Maximum speed
	n <sub>max</sub> in 1/min
Ø 24–31 mm	12000
Ø 31–40 mm	10000
Ø 40–51 mm	8000
Ø 51–68 mm	6500
Ø 67–87 mm	5000
Ø 87–116 mm	4000
Ø 116–153 mm	3000



**i** The specified maximum speeds refer to an overhang length of up to 4xD.

For longer overhangs the maximum speeds should be reduced as follows:

$$5xD = 80 \% n_{max}$$

$$6xD = 60 \% n_{max}$$

> 6xD identify with caution

### Maximum spindle speed for single point boring heads Ø 24–154 mm

Boring range	Maximum speed with unbalanced system	Maximum speed with Balanced System
	n <sub>max</sub> in 1/min	n <sub>max</sub> in 1/min
Ø 24–31 mm	9000	12000
Ø 31–40 mm	7500	10000
Ø 40–51 mm	5250	8000
Ø 51–67 mm	4000	6500
Ø 67–87 mm	3000	5000
Ø 87–116 mm	2500	4000
Ø 116–153 mm	1750	3000



### Large scale with 0.002 mm adjustment

How it works:

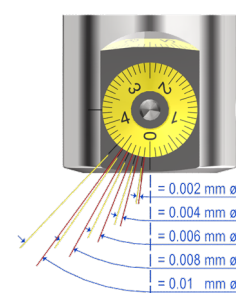
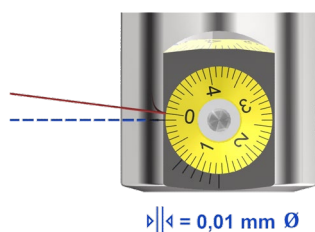

# Maximum overhang length LTA

▲ Clamping length 35 mm

Boring bar	High Speed Boring Head 62 361 ...																Fine boring head 62 304 ...		
	014	015	016	017	018	019	020	021	022	023	025	027	030	033	037	040	017	020	024
62 353 ...	56																		
008	63																		
009	70																		
010	77																		
011	84																		
012	91																		
013	98																		
014	98																		
016	112																		
018	112																		
118	112																		
218	112																		
																	115		
																	125		
																	105		
																	145		
																	185		

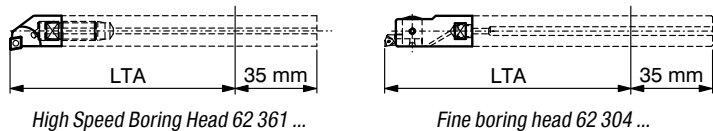

## Coatings

**K10**

- ▲ Carbide, uncoated
- ▲ ISO | **K10**
- ▲ Uncoated carbide grade for machining grey cast iron or non-ferrous metals, depending on the cutting edge geometry

**BK2710**

- ▲ Carbide, TiAlN-coated
- ▲ ISO | P10 | M10 | **K10**
- ▲ Extremely wear-resistant carbide grade for machining stainless steels, structural steels and tool steels as well as cast iron materials

**BK8440**

- ▲ Carbide, TiCN-TiN-coated
- ▲ ISO | **P35** | M10
- ▲ Very tough carbide grade for medium cutting speeds and interrupted cut

**BK7615**

- ▲ Carbide, TiCN-Al<sub>2</sub>O<sub>3</sub>-coated
- ▲ ISO | **K15**
- ▲ Highly productive grade with extreme edge stability for wet and dry machining of all cast iron materials

**TiN**

- ▲ TiN coating
- ▲ Maximum application temperature: 450°C

**CWN10**

- ▲ Carbide, TiN-coated
- ▲ ISO | **K10**
- ▲ The carbide grade for machining steels, stainless steels and non-ferrous metals

**CWC10**

- ▲ Cermet, uncoated
- ▲ ISO | **P15** | **M10** | K10
- ▲ The uncoated cermet grade for finish machining stainless and hardened steel
- ▲ Particularly wear resistant thanks to high heat resistance

**BK60**

- ▲ Carbide, TiC-TiCN-TiN-coated
- ▲ ISO | P25 | **M10**
- ▲ Multi-layer coating for long service life even in the upper cutting speed range

**CBN40**

- ▲ Cubic boron nitride, uncoated
- ▲ ISO | **H05**
- ▲ Uncoated cutting material made of cubic boron nitride for machining hardened steels over 45 HRC, heat-resistant nickel-based or cobalt-based alloys

**BK8425**

- ▲ Carbide, TiAlN/TiN-coated
- ▲ ISO | **P25** | **M25** | **K25**
- ▲ Universal grade with greater wear resistance thanks to innovative PVD multi-layer coating

**BK6110**

- ▲ Carbide, TiCN-TiN-Al<sub>2</sub>O<sub>3</sub>-coated
- ▲ ISO | P10 | **K10**
- ▲ Wear-resistant carbide for machining cast iron and steel materials

**CWC06**

- ▲ Cermet, TiC/TiN-coated
- ▲ ISO | **P10** | M10 | **K10** | N10
- ▲ Coated cermet grade for fine boring at high cutting speed and with a uniform cut

**CWP25**

- ▲ Carbide, uncoated
- ▲ ISO | **P25** | **M25** | K25 | **N25** | S25
- ▲ Uncoated carbide grade for fine boring with large hole depths and small machining allowances